

MI27 Plus Infusion Pump

User Manual

Version: 1.2

MDKMed Medical Technology Co., Ltd.
2025.1.2

Content

1 Symbols, Graphics and Warnings	5
1.1 Descriptions of Graphics and Symbols	5
1.2 Warning	6
2 Terms and Definitions	12
3 Brief Introduction and Scope of Application	13
3.1 Brief Introduction	13
3.2 Intended Use	13
3.3 Model Naming	14
3.4 Benefits	14
4 Important Features	15
5 Specifications	16
5.1 Basic Specifications	16
5.2 Main Performance	16
5.3 Main Functions and Common Functions	20
6 Structure and Operation Interface	21
6.1 Structural Composition	21
6.2 Display and Operation Interface	23
7 Operation Instructions	24
7.1 Installation of Infusion Pump	24
7.1.1 Installation of the mounting clamp	24
7.1.2 Installation of infusion pump	24
7.2 Power On and System Self-test	24
7.2.1 Power on and off	24
7.2.2 Device safety self-test	25











7.3 Quick Start Guide	25
7.3.1 Install/replace infusion set	25
7.3.2 Select infusion set	26
7.3.3 Set infusion parameters	27
7.3.4 Purge	28
7.3.5 Start Infusion	29
7.3.6 Infusion Completed	29
7.4 Pause or Stop Infusion	30
7.5 Bolus	31
7.5.1 Automatic bolus	31
7.6 Lock and Unlock Screen Function	32
7.7 Infusion Mode Selection and Setting	32
7.7.1 Dose Mode	33
7.7.2 Drug Library Mode	35
7.7.3 Drop Speed Mode	36
7.7.4 RTM Mode	36
7.7.5 Sequence Mode	37
7.7.6 Loading Dose Mode	38
7.7.7 Intermittent Mode	39
7.7.8 Relay Mode	40
7.7.9 Micro Mode	40
7.8 View Log	40
8 Alarms	41
8.1 Door Open Alarm	46
8.2 IV Set Setup Fail Alarm	47
8.3 Occlusion Alarm	47
8.4 Upstream Occlusion Alarm	48





8.5 End of Infusion Alarm	48
8.6 Air-in-line Alarm	49
8.7 Battery Empty Alarm	49
8.8 Battery/External power Disconnect Alarm	50
8.9 Motor Error Alarm	50
8.10 Communication Error Alarm	51
8.11 Battery Error Alarm	51
8.12 KVO Alarm	51
8.13 KVO End Alarm	52
8.14 Standby End Alarm	52
8.15 No AC Power Alarm	52
8.16 Call back alarm	53
8.17 Low Battery Alarm	53
8.18 Near End of Infusion Alarm	53
9 System Parameter Setting	54
9.1 Bed Number	54
9.2 Brightness	54
9.3 Alarm Sound Volume	54
9.4 Occlusion Pressure Level	55
9.5 Air Bubble Detection Sensitivity	55
9.6 Bolus Setting	56
9.7 Purge Setting	56
9.8 Call Back Time Setting	56
9.9 KVO Setting	57
9.10 Screen Lock Time	57
9.11 Near End of Infusion Time Setting	58
9.12 Prime Prompt Switch	59

9.13 History Mode Switch	59
9.14 IV Infusion Set Brand	59
9.15 Night Mode Setting	59
9.16 Date/Time Setting	60
9.17 System Maintenance	61
10 Accuracy Calibration for Infusion Set	61
10.1 Enter the Infusion set Accuracy Calibration Interface	61
10.2 Accuracy Calibration for IV infusion set	61
11 Precautions for Using Disposable Consumables	62
12 Technical Specifications	63
13 Restore to Factory Setting	72
14 Use, Maintenance and Uninstallation of the Internal Batteries	73
15 Service and Maintenance	73
16 Waste Disposal	75
16.1 Battery	75
16.2 IV Infusion Set	75
16.3 Infusion Pump	75
17 Electromagnetic Compatibility	75
18 Antistatic Precautions	82
19 Packaging and Accessories	84

1 Symbols, Graphics and Warnings

1.1 Descriptions of Graphics and Symbols

	<p>Caution</p>		<p>Read the User Manual</p>
	<p>Defibrillation prevention Type CF device</p>	<p>RoHS</p>	<p>Compliant to RoHS standards</p>
	<p>Date of manufacturing</p>		<p>Class II device</p>
	<p>Serial Number</p>		<p>Classified collection, uncontrolled discard not allowed.</p>
<p>IP24</p>	<p>Ingress Protection Grade</p>		<p>AC (Alternating Current)</p>
	<p>DC (Direct current)</p>		<p>Mute</p>

	Lithium battery		Manufacturer
	European Representative		CE mark demonstrating compliance with RoHS and other EU directives
	Medical device marking		

1.2 Warning

Please read the following information carefully, operation that does not strictly follow the guidance will possibly damage the device or do harm to patients' health.

- 1) The infusion pumps are intended to intermittently or continuously delivery the parenteral fluids, medications, blood and blood products via IV infusion route, delivery enteral fluids via the alimentary canal or any route connected to the gastrointestinal system (i.e., the enteral route). The devices can be used together with liquid storage devices /IV infusion sets /Blood transfusion sets /Enteral feeding sets. /Enteral feeding sets.
- 2) Untrained personnel are not allowed to operate the device. The device is only to be used by trained clinical professionals. The operator must carefully read this User's Manual, operate in strict accordance with the procedures required by the instructions, so as to prevent medical accidents caused by improper operation.

- 3) To prevent fire or explosion, do not use this device in an environment with flammable or explosive matters are present.
- 4) Do not stack and use other devices that may generate external radio frequency interference or electromagnetic radiation that may affect the safe operation of this device.
- 5) The operator must use the recommended IV infusion set calibrated in accordance with the requirements described in Section 10 Accuracy Calibration for IV Infusion Sets in this guide, and ensure that the correct IV infusion set brand and type are selected.
- 6) The IV infusion set that is not recommended should never be used for infusion, otherwise it may lead to large infusion inaccuracy and even to become unusable.
- 7) The installation height of this device should not be more than 1 meter above or below the patient's heart.
- 8) Do not reuse the same IV infusion set on another infusion device. Disposal of the single use IV infusion sets must be done according to the local environmental and waste disposal regulations.
- 9) This device cannot be used as a portable device.
- 10) Do not use sharp objects to press on the buttons or the touch screen.
- 11) It is recommended to regularly maintain the device. The MI27 Plus Infusion Pump must be serviced and calibrated by trained professional technicians. Before maintenance, make sure to unplug the power cable that supplies power to the device. Untrained personnel are strictly prohibited from opening the device casing, otherwise the eligibility for warranty of the device will be lost.
- 12) Please make sure to use only the parts and accessories provided

by MDKMed.

- 13) When hit hard or dropped, the pump should not be used until it has been checked by trained technical staff. In case there's damage, the device can be reused only if it is reconditioned under the responsibility of the manufacturer to comply with the general safety and performance requirements
- 14) Except for wiping the outer surface of the device according to Section 14 Service and Maintenance in this manual, no other part of the device shall be serviced or maintained by users. If there is any abnormality in the device, please contact the customer service of MDKMed.
- 15) During the use of this device, the device should be placed smoothly and fixedly.
- 16) After loading the IV infusion set, the operator is required to periodically check the fluid pathway and all connections for leaks which could cause under delivery or contamination. If there is leakage, stop using the IV infusion set and notify the customer service of MDKMed.
- 17) Operator should set the infusion parameters strictly based on the doctor's prescriptions. Mistakes in infusion parameter settings may cause harm to patients. All the parameters must be confirmed before infusion starts.
- 18) After setting infusion parameters, the operator must ensure that the infusion device is correctly installed on the device before starting the infusion.
- 19) In order to maintain a high infusion accuracy, the contacting spot of compression on an IV infusion set should be changed every 8

hours.

- 20) To maintain high infusion accuracy, the pump needs to be re-calibrated when there is a significant change in ambient temperature.
- 21) The pump will stop operation automatically when there is an alarm. Press the Start-Stop key to resume operation after the alarm causing condition is removed.
- 22) To avoid failure or false alarm caused by a dirty occlusion sensor or air- in-line sensor, operator should wipe clean the pump on a regular basis to keep it clean.
- 23) If the sound pressure level of the audible alarm is less than the environmental noise, the operator should turn the alarm volume up to ensure the alarm sound can be heard.
- 24) Pump or accessories may not be usable if their lifetime for use has expired (the lifetime for pump is 8 years). Contact MDKMed to upgrade to new products.
- 25) The device has a internal rechargeable lithium battery and its lifetime is 2 years.
- 26) Please check the voltage of the internal battery before using it for pump operation. The battery must be replaced and maintained by trained technical personnel in accordance with Section 14 Use, Maintenance and Removal of the Internal Battery in this manual. Replacing the battery by personnel without sufficient training will lead to risks such as over temperature, fire or explosion.
- 27) Please do not connect any other device to the USB port other than the enclosed DC power adapter shipped with the pump.
- 28) For different types of patients, different occlusion alarm pressure

threshold should be set, please refer to the doctor's advice for details.

- 29) Healthcare professional should check on the device during operation on a regular basis, and he/she should also pay attention to medication solution in the infusion set before starting the device to make sure the right medicine is in the right infusion channel.
- 30) Please use the roller clamp and other components on the infusion set correctly based on the corresponding instruction of the consumable per set.
- 31) When using this device, please do not plug the power to somewhere that is difficult to plug or unplug. Use an independent power outlet as a measure in case quick disconnection is needed.
- 32) IV infusion set needle is the application part of this product.
- 33) While in normal operation, an alarm will be triggered if the pump door is opened. Please contact MDKMed for service if this alarm fails to appear.
- 34) If the sticker on the screw hole is removed, then consider the fact that the pump has been tampered with, and discontinue use.
- 35) The product is not AP or APG type device and should not be used in flammable gas environment.
- 36) Don't use near active HF SURGICAL device and the RF shielded room of an ME SYSTEM for magnetic resonance imaging, where the intensity of EM DISTURBANCES is high.
- 37) Use of this device adjacent to or stacked with other device shall be avoided because it could result in improper operation. If such use is necessary, this device and the other device should be observed to verify that they are operating normally.

- 38) Use of accessories, transducers and cables other than those specified or provided by the manufacturer of this device could result in increased electromagnetic emissions or decreased electromagnetic immunity of this device and result in improper operation.
- 39) Portable RF communications device (including peripherals such as antenna cables and external antennas) should be used no closer than 30cm (12 inches) to any part of the MI27 Plus, including cables specified by the manufacturer. Otherwise, degradation of the performance of this device could result.
- 40) The EMISSIONS characteristics of this device make it suitable for use in industrial areas and hospitals (CISPR 11 class A). If it is used in a residential environment (for which CISPR 11 class B is normally required) this device might not offer adequate protection to radio-frequency communication services. The user might need to take mitigation measures, such as relocating or reorienting the device.
- 41) The ME device or ME SYSTEM is suitable for professional healthcare facility environments.
- 42) If the device needs to be used on the move (transport within the hospital): make sure the device is securely fixed and placed. If the device is changed in position, or the pump is severely shaken, the accuracy of the infusion may be affected.
- 43) Do not use unapproved cleaners, materials or chemicals as they may damage device surfaces, labels, or cause device failures.
- 44) Do not route LVP supply bag or administration set right above the pump.

- 45) Do not route the administration set in a way that presents tripping hazard and administration set break off.
- 46) Do not change the height of pump during infusion, otherwise the infusion accuracy may be affected.
- 47) For different types of patients, different occlusion pressure level should be set. For details, please refer to the doctor's advice.
- 48) When the device is powered by the internal battery, the charging indicator light is blue; When the device is powered through the net power supply, the external power indicator light will turn green. At this time, if the battery is not fully charged, the charging indicator light will turn green at the same time, and the charging indicator light will not turn on when the battery is fully charged.
- 49) Any serious incident that has occurred in relation to the device should be reported to the manufacturer and the competent authority of the Member State in which the user and/or patient is established.
- 50) Do not modify this equipment without authorization of the manufacturer.
- 51) If this equipment is modified, appropriate inspection and testing must be conducted to ensure continued safe use of the equipment.
- 52) If necessary, please contact the company's customer service staff to provide the relevant information of maintenance.

2 Terms and Definitions

Operator: A professionally trained and qualified member of medical staff.

Keep vein open (KVO): After infusion is completed based on the preset parameters, the pump will automatically switch to a mode with extremely low flow rate and continue to run (this mode virtually does not have any treatment effect), which is to keep the IV infusion set and vein unobstructed and to avoid the blood flowing backwards.

Intermediate rate: An infusion rate of 25 mL/h.

Minimum rate: An infusion rate of 1 mL/h.

Free-flow: Drug solution is flowing out in an uncontrolled manner under the effect of gravity.

VTBI: Volume to be infusion.

3 Brief Introduction and Scope of Application

3.1 Brief Introduction

MI27 Plus infusion pump is a smart infusion device. It is consisted of a pump outer housing, a motor actuation system, an input interface system, a storage system, a control system, a display system, a sensing and monitoring system, and an alarm system.

3.2 Intended Use

Intended use: The infusion pumps are intended to intermittently or continuously delivery the parenteral fluids, medications, blood and blood products via IV infusion route, delivery enteral fluids via the alimentary canal or any route connected to the gastrointestinal system (i.e., the enteral route).

The devices can be used together with liquid storage devices /IV infusion sets /Blood transfusion sets /Enteral feeding sets. /Enteral feeding sets.

Indication for use: N/A.

Contraindications: None.

Intended patient population: The target population is adults, pediatrics (including newborns) who need intravenous therapy, blood transfusion and enteral nutrition, no other specific requirements.

Intended users of the device: The device is intended to be used by trained healthcare professionals in medical institution environments.

3.3 Model Naming

MI 2 7Plus

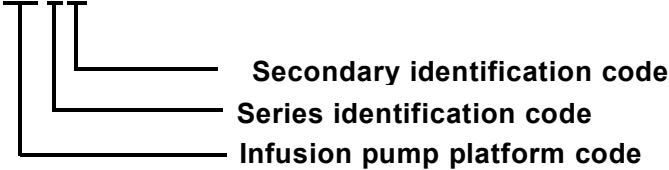

3.4 Benefits

Since the infusion pumps do not come into contact with patient directly, they don't have direct clinical benefit to patients. So the clinical benefit of the infusion pump is that the device enables the precisely administration of intravenous fluid /blood /blood product /enteral fluid procedure to be undertaken, and realizes the monitoring of the infusion

processing (the device is able to send alarms during infusion process when occlusion or other circumstances), which can greatly increase the infusion safety.

4 Important Features

- 1) **Accuracy:** The accuracy for both infusion rate and volume are kept within 4.8% when the IV infusion sets recommended by MDKMed are used.
- 2) **Flow rate:** Infusion rate can be adjusted from 1 mL/h to 2000mL/h in a continuous manner, which makes MI27 Plus capable of meeting various flow rate requirements in different infusion situations.
- 3) **External power supply:** An external power adapter is used, which not only removes the safety concerns of using an internal switching power source but also makes the device lighter and smaller in size.
- 4) **Battery capacity:** The rechargeable internal high-capacity Lithium battery can support normal operation for about 6 hours, which is conveniently helpful during patient transport or power outage.
- 5) **Display:** An LCD touch screen display offers high contrast, great visibility and user friendly usability.
- 6) **Occlusion alarm:** Both upstream and downstream occlusion alarms are available, 10 pressure level is adjustable.
- 7) **Air-in-line alarm:** Based on ultrasonic technology, the device is capable of detecting air bubble sizes down to 25 μ L and initiating air-in-line alarm.

5 Specifications

5.1 Basic Specifications

Dimensions	218 mm × 132 mm × 72 mm (W×D×H)
Weight	1.26 kg
Power supply	Network power supply: ~ 100 V-240 V, 50/60 Hz Internal battery:  7.4 V rechargeable Lithium battery
Power	55 VA
IV infusion set requirements	Refer to Section 11 Precautions for Using Disposable Consumables
Maximum flow rate	2000 mL/h

5.2 Main Performance

Setting range of infusion rate	0.01-2000.00 mL/h with resolution of 0.01 mL/h
Preset range of infusion volume	0.01 ~ 9999.99 mL with resolution of 0.01 mL
Infusion accuracy	±4.8%
Purge/Bolus rate	1 mL/h ~ 2000 mL/h, with resolution of 1 mL/h.
Purge VTBI / Bolus VTBI	0.10mL ~ 100.00mL with resolution of 0.01 mL
KVO Rate	This infusion pump provides two KVO modes to ensure venous patency while guaranteeing infusion safety: 1.Constant KVO Mode (V_{KVO} rate setting range:

0.10-5.00 mL/h, minimum step value 0.01 mL/h)
 -When the infusion rate is $>V_{KVO}$: After the infusion task is completed, the pump automatically runs at the V_{KVO} rate to maintain venous patency.

-When the infusion rate is $\leq V_{KVO}$: After the infusion task is completed, the pump continues to run at the infusion rate to maintain venous patency.

2.Variable Speed KVO Mode (V_{KVO} rate setting range: 0.10-5.00 mL/h, minimum step value 0.01 mL/h)

Users need to set the V_{KVO} rate separately for three scenarios:

- (a) $V_{KVO}(>10)$ rate for infusion rates > 10 mL/h,
- (b) $V_{KVO}(1-10)$ rate for infusion rates between 1-10 mL/h, and
- (c) $V_{KVO}(\leq 1)$ rate for infusion rates ≤ 1 mL/h.

The system will automatically matches the KVO rate based on the infusion rate:

-When the infusion rate is > 10 mL/h: After the infusion task is completed, the pump automatically runs at the $V_{KVO}(>10)$ rate to maintain venous patency.

-When the infusion rate is between 1-10 mL/h: After the infusion task is completed, the pump

	<p>automatically runs at the $V_{KVO}(1-10)$ rate to maintain venous patency.</p> <p>-When the infusion rate is ≤ 1 mL/h and the infusion rate is $> V_{KVO}(\leq 1)$ rate: After the infusion task is completed, the pump continues to run at the $V_{KVO}(\leq 1)$ rate to maintain venous patency.</p> <p>-When the infusion rate is ≤ 1 mL/h and the infusion rate is $\leq V_{KVO}(\leq 1)$ rate: After the infusion task is completed, the pump continues to run at the infusion rate to maintain venous patency.</p>
Time setting range	00 h 00 min 00s~ 99 h59 min 59s, with resolution of 1 s.
Occlusion pressure threshold	There are 10 levels in total, with the lowest being $30 \text{ kPa} \pm 20 \text{ kPa}$, and the highest being $120 \text{ kPa} \pm 20 \text{ kPa}$.
Maximum infusion pressure generated by the device	140 kPa
Triggering time of occlusion alarm and Bolus	<p>When operated at minimum flow rate (1.00mL/h): $< 1\text{h}$ when the occlusion alarm pressure threshold is set to the lowest pressure; or $< 3\text{h}30\text{min}$ when the occlusion alarm pressure threshold is set to the highest pressure.</p> <p>When operated at intermediate flow rate</p>

	<p>(25.00mL/h): < 1min30s when occlusion alarm pressure threshold is set to the lowest pressure, and the Bolus produced by occlusion is < 0.20 mL; < 2min30s, when the occlusion alarm pressure threshold is set to the highest pressure, the Bolus produced by occlusion is not more than 0.40 mL.</p> <p>(Tested with the Hanaco IV infusion set when an occlusion occurred 1 meter away from the pump outlet for testing purpose at 20 °C)</p>
Consumable brand	<p>IV infusion set: 5 brands are recommended, and the default brand is Hanaco, JR, Kindly, Kang Jin, Shinva. 10 brands can be customized.</p> <p>enteral feeding set: MDK</p> <p>blood transfusion set: Terumo</p>
Supported infusion modes	<p>10 modes, including RVT mode, Drug library mode, Dose mode, Drop speed mode, RTM mode, Sequence Mode, Loading dose mode, Intermittent mode, Relay mode and Micro mode.</p>
Battery running time	<p>Intermediate rate (25.00mL/h): When fully charged, the battery can run continuously for 6h30min.</p> <p>Maximum rate (2000mL/h): When fully charged, the battery can run continuously for 6h10min.</p>
Automatic recovery time for alarm mute	<p>2min±10s</p>
Classification	<p>Type II CF continuous operating volumetric</p>

	infusion pump with internal power supply; Grade IP24, Non-AP, APG type device.
Ambient temperature, humidity and pressure	Ambient temperature of transportation and storage: -20 °C ~ + 55 °C Ambient temperature for operation: +10 °C ~ + 40 °C Ambient humidity for transportation, storage and operation: 20% ~ 90% Ambient pressure for transportation, storage and operation: 700 hPa ~ 1060 hPa
Software version	MI27 Plus-V1
Product lifetime	8 years

5.3 Main Functions and Common Functions

- 1) Set infusion rate, infusion volume preset and real-time data display function;
- 2) Display of completed infusion volume;
- 3) Purge/Bolus;
- 4) Alarms;
- 5) The flow rate will be automatically changed to KVO Rate after the VTBI complete alarm is activated;
- 6) Temporary mute for alarm sound and timer for alarm sound recovery;
- 7) Automatic free-flow stopping function;
- 8) Display the total volume infused;
- 9) Remove the total volume infused data;
- 10) Compatibility of varies of brands of IV infusion sets;

- 11) Built-in battery;
- 12) External power adapter;
- 13) Dose-error Reduction Software.

6 Structure and Operation Interface

6.1 Structural Composition

The device is consisted of a pump casing, a motor actuation system, an input interface system, a storage system, a control system, a display system, a sensing and monitoring system, and an alarm system.

Names for parts and components:

1	Operation status indicator	2	Touch screen display	3	External power indicator
4	Charging indicator	5	Start-Stop key	6	Power On/Off key
7	Door lock switch	8	Air bubble sensor	9	Clamp
10	Downstream occlusion sensor	11	Pump door latch	12	Pump discs
13	Positioning groove for IV infusion set	14	Upstream occlusion sensor	15	Mounting bolt
16	DC power port	17	Data communication port	18	Pump door

19	Drip sensor	20	Stack slot		
----	-------------	----	------------	--	--

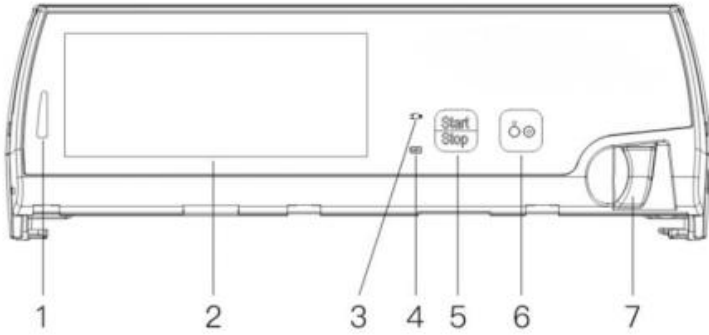

Figure 6-1-1 Front view

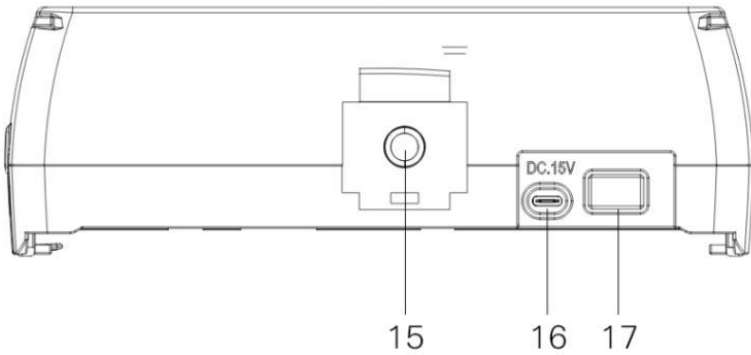

Figure 6-1-2 Rear view

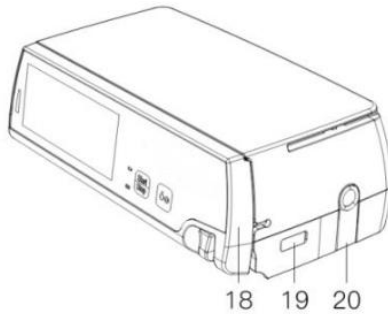

Figure 6-1-3 Side view

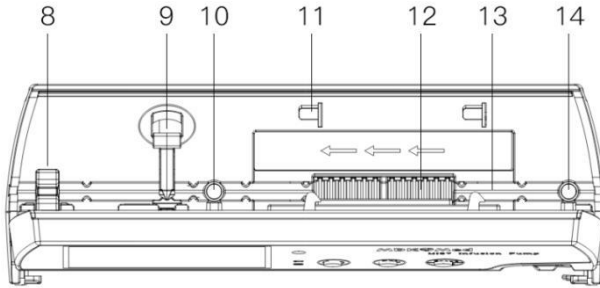

Figure 6-1-4 Front view with pump door opened

6.2 Display and Operation Interface

The interface during operation is shown in Figure 6-2.

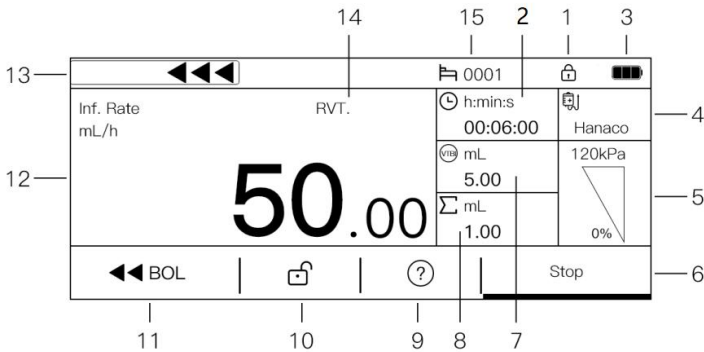

Figure 6-2 Operation interface on the screen

1	Lock screen	2	Time remaining	3	Battery
4	brand	5	Occlusion pressure	6	Start/Stop button
7	Remaining volume	8	Infused volume	9	more information
10	Unlock	11	Purge/Bolus	12	Rate
13	Infusion state	14	Infusion mode	15	Bed number

7 Operation Instructions

Install infusion pump → power on → device safety self-test → parameters setting → install IV infusion set → fast infusion to purge air bubbles out → start infusion → infusion completed → remove accessories → power off.

Before infusion starts, please confirm that the IV infusion set in use matches the current IV infusion set setting selected in the menu. Any IV infusion set which brand is not included in the list of recommended brands must be calibrated before being used.

7.1 Installation of Infusion Pump

7.1.1 Installation of the mounting clamp

The mounting clamp is a separate accessory. First loosen the locking screw, install the clamp to the pole of the infusion stand, adjust the height of clamp, and then tighten the locking screw.

7.1.2 Installation of infusion pump

Install the pump to the IV infusion stand by inserting the mounting bolt on its back into the hole on the mounting clamp. The operator must make sure that the infusion pump is positioned in a secure, stable and reliable manner.

7.2 Power On and System Self-test

7.2.1 Power on and off

Before connecting to the mains power, check if there is any foreign matter inside the power outlets (such as drug solution

residue).

Connect to the mains power, check the power indicator on the pump front panel. If the indicator is not lit up, check the connection of power cable and the pump, or check if there is a power outage. Then press the power key on the front panel to turn the device on.

After infusion therapy is completed, press and hold the power key for at least 3 seconds to turn the device off. Do not power off when the device is in operation mode, otherwise the infusion therapy will be stopped.

7.2.2 Device safety self-test

The pump will perform an automatic safety self-test after powered on, if the test is passed then there will be two short beeps. If a continuous alarming sound is initiated or there is no any sound at all, then the device cannot be used, contact the customer service at MDKMed immediately.

7.3 Quick Start Guide

7.3.1 Install/replace infusion set

First, open the pump door by unlocking the door lock on the right hand side of the infusion pump. Straighten the infusion line below the drip chamber and place it into the positioning groove. Then close the pump door, adjust the roller clamp on the IV infusion set to its open position. The installation of IV infusion set is completed.

Before changing IV infusion set or changing drug solution, the roller clamp on the IV infusion set has to be turned to the closed

position to prevent free flow of the medication solution.

To change or re-install the IV infusion set, first open the pump door, push the clamp inside pump door upward to open it and to release the infusion line. Install the IV infusion set back into the pump again, and adjust the roller clamp on the set to the open position after the IV infusion set installation is done.

7.3.2 Select infusion set

After the infusion pump is powered on and the safety self-test is passed, the parameter setting page will show up. Press on the Brand button in the upper right corner to enter the IV infusion set brand selection page.

After pressing on an IV infusion set brand to make a selection, the system will automatically return to the parameter setting page. Please double check if the IV infusion set displayed on the right side of the screen matches the set that is being used.

It is possible that the IV infusion sets from the same brand may have different characteristics if they are from different lots, which will affect their infusion accuracy if they are not calibrated before use. In that case, calibration of the IV infusion set is recommended, which is described in Section 10.2 Accuracy Calibration for IV Infusion Sets.

IV Set Brands		
Hanaco		↑
		—
		↓
		—
		↶

Figure 7-3-2 Selection of infusion set

7.3.3 Set infusion parameters

General method:

When the infusion pump is standby, click "☑" on the touch screen to enter the RVT mode parameter setting interface. Click "Inf. rate" on the touch screen, a numeric button board appears on the screen, click to enter the value of the flow rate to be set, and press "√" on the screen to complete the input.

Setting the VTBI and infusion time is the same as setting the infusion rate above. After all parameters are set, click the "√" button to confirm the parameters.

Quick setting method:

When the infusion pump is standby, click "Inf. rate" value on the screen, and a numeric button board appears. Click to enter the value of the Infusion rate to be set, and press "√" on the screen to complete the input.

RVT.			
Inf. Rate	---	mL/h	✓
VTBI	---	mL	
Inf. Time	--:--:--	H:M:S	
			↶

Figure 7-3-3-1 Set infusion parameters

1	2	3	⊗
4	5	6	↶
7	8	9	✓
.	C	0	

Figure 7-3-3-2 Input values using keypad

7.3.4 Purge

When the pump is standby, confirm that the IV infusion set is disconnected from the patient and press the Bolus button. The pump pops up “Please disconnect IV Set!”, after clicking “√” on the touch screen, the pump will run at the flow rate and total volume set by the system to quickly remove the air bubbles in the infusion pipeline. Click the pause button can stop.

The total volume of purge would not be included in the data of the cumulative volume of infusion. During purge operation, the bubble alarm is suppressed and not reported, but other alarms are normal.

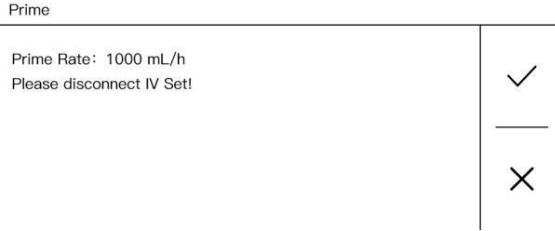

Figure 7-3-4 Purge the IV infusion set

7.3.5 Start Infusion

Press the Start-Stop key or click the start button and the pump will start to operate according to the set infusion parameters, as shown in the following figure.

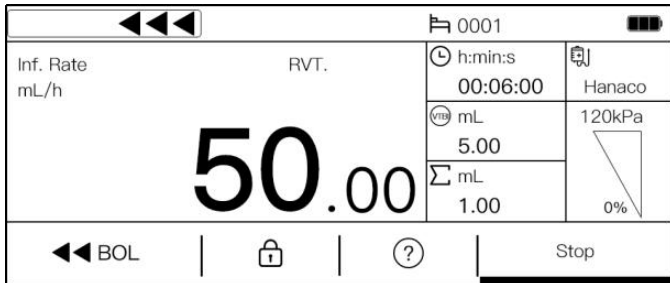

Figure 7-3-5 Infusion operation interface

7.3.6 Infusion Completed

When the total infusion volume (the incremental of infused volume) has reached the set value, the device completes the infusion.

If KVO is turned on, the device will convert to the KVO Rate to continue running automatically and trigger high priority alarm at the

same time, make an alarm sound. Click the "√" on the touch screen to exit the KVO infusion status.

If KVO is not turned on, the device will trigger an "End Of Infusion" alarm, accompanied by an high priority alarm sound. Click the "√" on the touch screen eliminates alarm.

After the infusion is completed, remove the infusion accessories that are no longer used following the steps described in Section 7.3.1. Press the power on/off key, click power-off button to turn off the device. Pull the ring on the base of the mounting clamp upward and pull the infusion pump body outward to remove it.

7.4 Pause or Stop Infusion

Press the Start-Stop key during infusion operation to pause the infusion, as shown in the following figure.

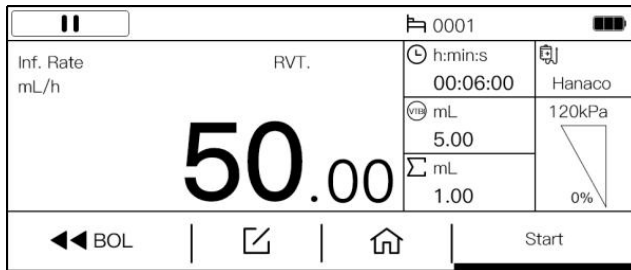

Figure 7-4 Infusion pause

On the Infusion pause page, press the Start-Stop key or click the start button again can start the device operation, and the device will continue to infuse the remaining volume based on the set flow rate.

During the infusion pause, any parameter of the infusion rate, total volume, and time is modified will be considered a new infusion

task, and when press the Start-Stop key or click the start button again, the infusion task will be completed according to the new infusion parameters.

When the device triggers an alarm, makes an alarm sound, presses the "Mute" button on the screen can pause the alarm sound, and after 2 minutes, if the alarm source is not lifted, the alarm sound is automatically restored.

7.5 Bolus

7.5.1 Automatic bolus

When the infusion pump is running, click the "Bolus" button, enter the bolus flow rate and volume of setting page, set the bolus flow rate parameters, press the "√" button, the infusion pump enter into bolus infusion state until the bolus infusion volume is completed, the infusion pump returns to the normal infusion state continue the infusion, the bolus volume is included in the infusion accumulative volume.

Hand Off Bolus			
Bolus Rate	---	mL/h	✓
Bolus VTBI	---	mL	
Bolus Time	--:--:--	H:M:S	
			↶

Figure 7-5-1-1 Bolus Settings interface

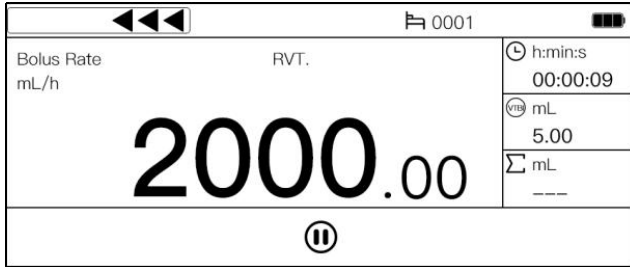

Figure 7-5-1-2 Bolus running interface

7.6 Lock and Unlock Screen Function

The device will be locked automatically after running for a certain period of time. When the device is in the lock screen, clicking the screen will pop up a prompt on whether to unlock the screen, click the "√" button to unlock the screen.

Auto Lock time settings See Home - Setting - Auto Screen Lock.

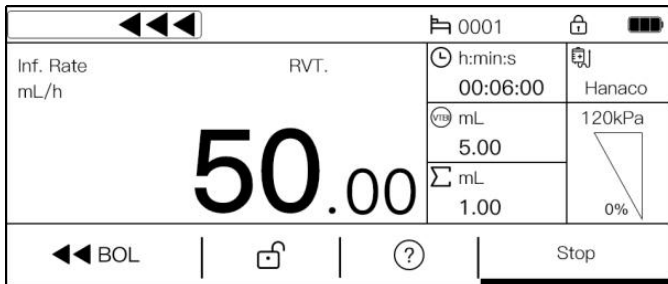

Figure 7-6 Lock screen

7.7 Infusion Mode Selection and Setting

MI27 Plus has 10 infusion modes, including RVT mode (intravenous therapy, blood transfusion and enteral nutrition), drug library mode, dose mode, drop speed mode, RTM mode,

Sequence mode, loading dose mode, intermittent mode, relay mode and micro mode.

There are four secondary modes under the RVT mode based on different combinations of flow rate, infusion volume and infusion time, which are the Rate – Volume (R+V) Mode, the Rate – Time (R+T) Mode, the Volume – Time (V+T) Mode and the Rate (R) Mode.

Therefore, there are 13 different infusion modes for the device in total.

Please follow this User's Manual in the Quick Start Guide in the previous sections for how to set in the flow rate mode. The following is a brief instruction for how to set the other modes.

For blood transfusion and enteral nutrition, install the special sets according to 7.3.1 Operation instructions, and select the consumables brands according to the operation instructions in Section 7.3.2. Click Home-Infusion Mode - RVT Mode to enter the page of mode parameter setting.

7.7.1 Dose Mode

Select to enter the body weight mode setting screen, as shown in Figure 7-7-1-1; 7-7-1-2. Based on the prescriptions given by doctor, input information such as Dose, Concentration, Weight and Volume. The device will automatically calculate the flow rate for infusion. Then input the total volume of infusion. After setting the parameters, click "√" to confirm the infusion parameters.

In addition, the device also supports the input of concentration, weight, infusion rate and other parameters, to automatically

calculate the dose rate

Dose		1/2		
Conc.	---	mg/mL		✓
Weight	---	kg		^
Dose Rate	---:---	mg/kg/mL		∨
Inf. Rate	---	mL/h		↶

Figure 7-7-1-1 Dose mode setting page (a)

If the doctor's prescription does not include information for the concentration, press the Concentration button to enter the following page to set the Drug Dosage and Solvent Volume. The device will automatically calculate the Concentration parameter and display it on the dose mode setting page. Press the arrow button on the lower left corner to return to the previous page.

Dose		2/2		
VTBI	---	mL		✓
				^
				∨
				↶

Figure 7-7-1-2 Dose mode setting page (b)

In the Dose Mode Settings interface, click "Unit" to the right of any parameter in "Dose", "Concentration" and "Dose Rate" to select different unit expression modes, and the other two corresponding units will be automatically adjusted.

Concentration calculation formula:

$$\text{Concentration(mg/mL)} = \frac{\text{Dose (mg)}}{\text{Solution (mL)}}$$

Infusion rate calculation formula:

Infusion Rate(mL/h)

$$= \frac{\text{Dose Rate (mg/kg/h)} \times \text{weight (kg)} \times \text{Solution (ml)}}{\text{Dose (mg)}}$$

$$\text{Infusion Rate(mL/h)} = \frac{\text{Dose Rate (mg/h)} \times \text{Solution (ml)}}{\text{Dose (mg)}}$$

7.7.2 Drug Library Mode

Enter the drug library mode settings interface. First, select the name of the drug that requires infusion, and then select the specific specifications of the drug.

The device goes to the drug library mode settings page and automatically brings in the drug-related parameters. At this point, the drug name and drug specifications are displayed in the title bar of the parameter settings page. Once the parameters are set, click the "√" button to confirm the infusion parameters, press the Start-Stop button or click the Start button to start the infusion.

ADREnaline		1/2		
Conc.	----	mg/mL		✓
Weight	----	kg		^
Dose Rate	----:---	mg/kg/mL		∨
Inf. Rate	----	mL/h		↶

ADREnaline		2/2		
VTBI	---	mL		✓
				^
				∨
				↶

Figure 7-7-2 Drug library mode setting page

7.7.3 Drop Speed Mode

The drop speed mode setting page is shown in Figure 7-7-3. After the drop speed parameter is set, the system will automatically convert it to a flow rate and display it. The other steps for the settings in this mode are the same as those in the flow rate mode described in the Quick Start Guide section.

Drip			
VTBI	---	mL	✓
Drop Rate	---	dot/min	
Inf. Rate	---	mL/h	
			↶

Figure 7-7-3 Drop speed mode setting page

7.7.4 RTM Mode

The RTM mode setting page is shown in Figure 7-7-4.

RTM.		1/2	
Total Time	--:--:--	H:M:S	✓
Up Time	--:--:--	H:M:S	^
Dwon Time	--:--:--	H:M:S	v
VTBI	---	mL	↶
RTM.		2/2	
Plateau Rate	---	mL/h	✓
			^
			v
			↶

Figure 7-7-4 RTM mode setting page

In the RTM mode parameters, VTBI, Up Time, and Down Time must be set. After setting one of the two parameters of Plateau rate or Total Time, the other parameter will be calculated automatically. After setting the parameters, click "√" to confirm the parameters.

When the device is started, the infusion rate gradually increases from 0 to Plateau Rate during the Up Time and then maintains the rate. When the remaining time is equal to the Down Time, the infusion rate gradually decreases until it reaches 0 and the infusion is completed.

7.7.5 Sequence Mode

Enter the Sequence Mode settings interface to set the number of sequences (up to 10 groups), click the "√" button to enter the infusion parameter settings interface, as shown below:

Sequence		1/3	
Seq. Count	1		✓
			^
			v
			↶

Figure 7-7-5-1 Sequence Mode Setting 1

Sequence		2/3	
S1-Inf. VTBI	---	mL	✓
S1-Inf. Time	--:--:--	H:M:S	^
S1-Inf. Rate	---	mL/h	v
			↶

Figure 7-7-5-2 Sequence Mode Setting 2

Sequence		3/3	
Total VTBI	---	mL	✓
Inf. Time	--:--:--	H:M:S	^
			∨
			↶

Figure 7-7-5-3 Sequence Mode Setting 3

As shown in the figure, Set any two of the Infusion VTBI, Infusion Rate, Infusion Time, the device will automatically calculate another parameter.

After setting infusion parameters for all sequences according to clinical needs, click "✓" to confirm the parameters.

When the device completes the infusion parameters of the first sequence, it automatically switched to the parameter run of the second sequence until the set parameters of all sequences were completed and the infusion is completed.

7.7.6 Loading Dose Mode

Select to enter the loading dose mode setting page, as shown in Figure 7-7-6.

Loading Dose		1/2	
VTBI	---	mL	✓
Loading VTBI	---	mL	^
Loading Rate	---	mL/h	∨
Maintain Rate	---	mL/h	↶

Loading Dose		2/2	
Loading Time	---	mL/h	✓
Maintain Time	--:--:--	H:M:S	^
			∨
			↶

Figure 7-7-6 Loading dose mode setting page

As shown in the figure, After setting the VTBI, Loading VTBI, Loading Rate, and Maintain Rate, the device automatically calculated the Loading Time and Maintain Time, and click the "√" button to confirm the infusion parameters.

7.7.7 Intermittent Mode

Select to enter the intermittent mode setting page, as shown in the following figure.

Intermittent			
Single VTBI	---	mL	✓
Single Rate	---	mL	
Inter Time	---	mL/h	
Maintain Rate	---	mL/h	↶

Figure 7-7-7 Intermittent mode setting page

As shown in the figure, set the Single VTBI, Single Rate, Intermittent Time and Maintain Rate, and click the "√" button to confirm the infusion parameters. After the device is started, the infusion will start at the Single Rate. When the infused volume reached to the single VTBI, the device will automatically continue infusion according to the Maintain Rate. When the Maintain Rate is set to 0, the device will run at 0 mL/h. The device runs at Maintain

Rate until the time reached to the Intermittent Time, the device automatically switches to the Single Rate to continue the infusion, and repeat in circulation until the total VTBI completed.

7.7.8 Relay Mode

The MI27 Plus Infusion pump can be used on our infusion workstation for advanced application functions such as relay infusion and drug library management through the Infusion Information Collection System.

7.7.9 Micro Mode

Enter Micro mode settings interface.

Set any two of the Infusion Rate, VTBI, and Infusion Time, the device will automatically calculate another parameter. The Infusion Rate should not exceed 100mL/h. After the device is started, the infusion starts at the Infusion Rate. When the infused volume is equal to the VTBI, the infusion will be stopped automatically.

When only sets the Infusion Rate, the device runs at the Infusion Rate until the operator stops the infusion or the device triggers a high priority alarm to stop the infusion.

7.8 View Log

In the HOME- Event Log page, event logs such as device infusion status and alarm can be displayed. Click the event can view the detailed event information such as Infusion Rate, VTBI, time, Alarm priority and time.

Through the infusion information collection system, all infusion and alarm log information can be stored and queried in unlimited,

and the log information can be printed out on the Internet to facilitate the needs of medical management. With the Pump Log APP, you can connect your device to your phone, download logs to your phone for administrative viewing, printing, and more.

EventLog			1/3
Low Battery	2020-01-01	>	^
Call Back Alarm	2020-01-01	>	—
Low Battery	2020-01-01	>	v
Low Battery	2020-01-01	>	↶

Figure 7-8 Event log

8 Alarms

Alarm refers to the infusion changes caused by the abnormal infusion circuit or the failure of the infusion pump itself, which leads to the failure of the infusion to the patient. The infusion pump prompts the medical staff through sound, light, screen signs and other ways.

Alarm classification prompts of the device:

No.	Alarm	Priority	Alarm Category	Alarm condition
8.1	Door Open	High	Latching	The pump door is not closed during operation or purge.
8.2	IV-Set Setup Fail	High	Latching	Pump starts to operate without an IV infusion set being

				installed.
8.3	OCCL (occlusion)	High	Latching	When the downstream infusion line is occluded.
8.4	Upstream Occlusion	High	Latching	When the upstream infusion line is occluded.
8.5	End of Infusion	High	Latching	The preset infusion volume has been delivered for a single infusion.
8.6	Air-in-line	High	Latching	Air bubbles are detected in the line or an occlusion takes place in the upstream infusion line.
8.7	Battery Empty	High	Latching	When the internal battery is running out.
8.8	Battery&External Power Disconnect	High	Unlatching	When both the internal battery and the external power source fail to supply power to the device during operation.
8.9	Motor Err.	High	Latching	When the motor fails.
8.10	Com. Err. (Communication	High	Latching	When communication failure

	error)			is detected by the system monitor.
8.11	Battery Error	High	Latching	No internal battery is detected or the internal battery fails.
8.12	KVO	High	Latching	Start infusion until the total volume complete. When the KVO is turned on, the alarm will be triggered then.
8.13	KVO End	High	Latching	Run in KVO status for 30 minutes and the alarm will be triggered once KVO is completed,
8.14	Standby End	High	Latching	Start standby, set a short time, after reach the set time, the alarm will be triggered.
8.15	No AC power	Low	Unlatching	If the device is not connected to an external power supply and is powered by a battery, an alarm will be triggered.
8.16	Call Back	Low	Unlatching	When the device is

				powered on but no operation has been carried out since then for two minutes
8.17	Low Battery	Low	Unlatching	When the internal battery power is low.
8.18	Near End of Infusion	Low	Unlatching	When the remaining time is less than or equal to the preset alarm time during infusion.

The device alarm indicator characteristics:

Alarm priority	Indicator color	Flicker frequency		Rate
High priority	Red	2 Hz	0.7 Hz (Battery & External Power Disconnect)	50%
Medium priority	/	/		/
Low priority	Yellow	Normally turned on		100%

High priority and low priority alarms are distinguished by different sound and light indications based on the requirements from the related standards. When an alarm occurs, the operator should be able to notice it 1 m away from the device. The time for triggering an alarm shall not be more than 2 sec.

The pump will perform an automatic safety self-test after power on,

two short beeps will be heard if the test is passed, which means the alarm system is working normally. If the operation status indicator is not lit or a continuous alarm sound is initiated or there is no any sound at all, then there could be a failure in the alarm system. In that case, the device cannot be used until the problem is fixed. The sound pressure for the audible alarm ranges from 60 to 95 dB.

Please note that any attempt to access or to change the alarm system is not allowed for this device. Alarms will be carried out based on the last settings during the process when changes to alarm settings are being made by the operator.

=====



Attention

Latching alarm: the alarm that will remain even though the condition that triggered it does not exist anymore, until the operator intentionally ends the alarm (press the Start/Stop key); unlatching alarm: the alarm that will stop automatically when the condition that triggered it has been remove.

The priority of an alarm:

If a high-priority alarm is triggered when the device is giving out a low-priority alarm, the low-priority one will be interrupted to give way to the high-priority one. Both alarm sound and displayed message will be replaced by those of the high-priority alarm.

If a low-priority alarm is triggered when the device is giving out a high-priority alarm, the high-priority one will continue without being interrupted, including both its alarm sound and displayed message.

If a low-priority alarm is triggered when the device is giving out a low-priority alarm, the alarm sound of first low-priority one will continue without being interrupted, but the displayed alarm message will be replaced by that of the second one.

Both visible and audible alarms will be carried out right away when an alarming condition is detected by the system.

If the device is out of power for less than 30 sec, then all the values in the alarm settings will remain when power is restored.



8.1 Door Open Alarm

Cause: While in operation, if the pump door is not closed, or the pump door is opened by accident, then a high-priority alarm sound will be given out by the device, the infusion will be stopped, and a Door Open alarm message will be displayed on the screen. The status indicator will be flashing in red color at the same time.

Solution: During the door open alarm, press the Start/Stop key or press the Ack button on the screen to mute the alarm sound and to clear the Door Open alarm message. Check the pump, close pump door and continue to operate.

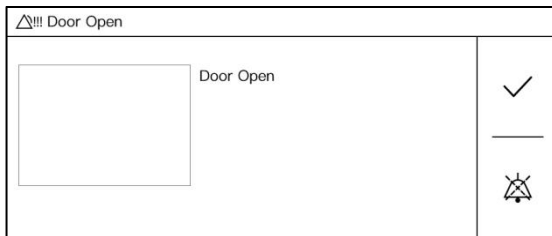

Figure 8-1 Door open alarm

8.2 IV Set Setup Fail Alarm

Cause: When operation is started without an IV infusion set being installed on the pump, a high-priority alarm sound will be given out by the device, operation will be stopped, and a IV-Set Setup Fail alarm message will be displayed on the screen. The status indicator will be flashing in red color at the same time.

Solution: Click the “√” button on the screen to clear the alarm, the word "IV-Set Setup Fail" disappears, and returns to the infusion pause interface. Open the pump door and install the IV infusion set before continuing.

8.3 Occlusion Alarm

Cause: When the infusion line is occluded, the occlusion sensor will detect this condition and activate an alarm. A message "OCCL" will be displayed on the screen, the status indicator will be flashing in red color and the pump will stop infusion. As a safety measure at the same time, the motor will rotate in the opposite direction to retrieve a small amount of drug solution to reduce the Bolus volume before occlusion is removed.

Solution:

- 1) Click the "√" button on the screen to clear the alarm and the message "OCCL" disappear.
- 2) Check whether the infusion line is kinked or the patient is pressing on the infusion line by accident.
- 3) If there is still an occlusion alarm, shut off the roller clamp on the IV infusion set, open the pump door, pull out the IV infusion set, check whether the filter or the needle on IV infusion set is occluded,

change to a new IV infusion set if necessary and restart infusion.

8.4 Upstream Occlusion Alarm

Cause: When the roller clamp between the bag and the pump is left closed by mistake, the infusion line will become flat when the infusion gets started. Then an upstream occlusion alarm will be triggered and an “Upstream Occlusion” alarm message will be displayed on the screen. The infusion will stop while the device is giving out a high-priority alarm sound and a flashing red light alarm signal.

Solution:

- 1) Click the “√” button on the screen to clear the alarm and the message "Upstream Occlusion" disappear.
- 2) Check if the IV infusion set is kinked, or if the roller clamp is opened, or if the infusion bag has any drug solution remaining. Restart infusion when everything is back to normal.

8.5 End of Infusion Alarm

Cause: When the accumulated infusion volume shown in the current display window reaches the preset value, the pump will give out a high-priority alarm sound and a flashing red light alarm signal. The infusion based on the preset flow rate will be stopped and a “End of Infusion” alarm message will be displayed on the screen.

As a safety and protection measure, the pump will automatically switch to KVO mode to continue infusion.

Solution: Click the "√" button on the screen to clear the alarm and the message "End of Infusion" disappears. The device can be

set up and used again.

8.6 Air-in-line Alarm

Cause: During pump operation, when the air-in-line sensor detects that the size of air bubble is larger than that of the preset limit, infusion will be stopped. The pump will initiate an air-in-line alarm sound and display Air-in-Line alarm message on the screen. The status indicator will be flashing in red color at the same time.

Solution:

- 1) Click the “√” button on the screen to clear the alarm sound and the message "Air-in-line" disappears.
- 2) To remove air bubbles from the infusion line, close the roller clamp, open pump door, take IV infusion set out, check whether there is air bubbles in the line, shake and move the air bubbles to the drip chamber by hands if there is, reinstall the IV infusion set, close the pump door, open the roller clamp and press the Start/Stop key to restart infusion.
- 3) Check if the air-in-line sensor is clean. If sensor probe is dirty, uninstall the IV infusion set, wipe clean the sensor probe with alcohol, reinstall the IV infusion set, and restart infusion.
- 4) If the alarm remains, change to a new IV infusion set, install the IV infusion set and restart.
- 5) The air-in-line alarm will be activated too if the infusion line between the infusion bag and the pump is occluded. Remove the occlusion in infusion line and restart infusion.

8.7 Battery Empty Alarm

Cause: When the internal battery is running out, the device will

initiate a high-priority alarm sound and start a flashing red light alarm signal, while displaying an Battery Empty alarm message on the screen. Infusion will be stopped. The pump operation will remain in stop and it will completely shut down in three minutes.

Solution: Connect to mains power for power supply immediately. When connected to mains power, the battery charging indicator will be lit up while the battery is being charged, which will go off when battery is fully charged.

8.8 Battery/External power Disconnect Alarm

Cause: When pump is in operation, and when the mains power is disconnected and the battery is completely out or disconnected too, the system will initiate a high-priority alarm sound, the screen will be turned off and the status indicator will be flashing in red color. The sound and light alarms will continue for three minutes before the system completely shuts down.

Solution: Connect to mains power or use backup battery to supply power.

8.9 Motor Error Alarm

Cause: When an error is detected in the motor feedback signal (too fast or too slow, or spinning in the wrong direction or etc.), a high-priority alarm sound will be triggered and a flashing red light alarm signal will be started, while a Motor Error alarm message will be displayed on the screen.

Solution: Click the "√" button on the screen to clear the alarm. Start the infusion again, still report the fault alarm, please contact

our service personnel.

8.10 Communication Error Alarm

Cause: When a communication failure is detected by the system monitor, a high-priority alarm sound will be triggered and a flashing red light alarm signal will be started, while a Communication Failure alarm message will be displayed on the screen.

Solution: Long press and hold the power on/off key to shut down the device after restarting, still report the fault alarm, please contact our service personnel.

8.11 Battery Error Alarm

Cause: If the internal batter is not detected by the system or if the battery fails, a high-priority alarm sound will be triggered and a flashing red light alarm signal will be started, while a Battery Error alarm message will be displayed on the screen.

Solution: Click "√" button on the screen to clear the alarm sound. Press the Power on/off key to shut down the device and restart the device. If the fault alarm is still reported, please contact our service personnel.

8.12 KVO Alarm

Cause: When KVO is enabled and the infusion is complete, the device will automatically convert to the KVO Rate to continue operation. At the same time, the device will trigger high priority alarm and sound alarm, the screen appear with the message

"KVO" and the operation status indicator will flash red at the same time.

Solution: Click the "√" button on the screen to clear the alarm. The message "KVO" disappear. The device can be reset according to operating steps.

8.13 KVO End Alarm

Cause: When the KVO state runs for 30 minutes until KVO task is completed, the device will trigger an alarm, stop running, make a high priority alarm sound, the screen appear with the message "KVO End" and the operation status indicator flash red at the same time.

Solution: Click the "√" button on the screen to clear the alarm. The message "KVO End" disappear. The device can be reset according to operating steps.

8.14 Standby End Alarm

Cause: When the device is in standby status and the standby time is over, the device will trigger high priority alarm, the screen appear with the message "Standby End" and the operation status indicator flash red at the same time.

Solution: Click the "√" button on the screen to clear the alarm.

8.15 No AC Power Alarm

Cause: When the device is powered on without the network power and use battery power supply, the device will trigger an alarm, make a low priority alarm sound, the screen appear with the

message "No AC Power" and the operation status indicator steady on yellow at the same time.

Solution: Click the "√" button on the screen or connect to an external power supply to clear the alarm.

8.16 Call back alarm

Cause: The device is ready to start the infusion, but the device is not started and the device is placed without operation for the set time, the device will trigger an alarm, make a low priority alarm sound, the screen appear with the message "Call Back" and the operation status indicator steady on yellow at the same time.

Solution: Click the "√" button on the screen to clear the alarm.

8.17 Low Battery Alarm

Cause: When internal battery is low, the device will announce a low-priority alarm sound and display a Low Battery alarm message on the screen. If infusion is in progress, the pump will continue to run.

Solution: Connect to mains power immediately. When connected to mains power, the battery charging indicator will be lit up, the battery will start to be charged, and the Low Battery message will disappear. The battery charging indicator will go off when it is fully charged.

8.18 Near End of Infusion Alarm

Cause: When the remaining time is less than the preset alarm time, the device will initiate a low-priority alarm sound, and display a Near End alarm message on the screen. Infusion will not be stopped.

Solution: Press the Start/Stop key or press the Ack button on the screen to clear the alarm. Check on the remaining drug solution and the remaining time. Wait until the infusion is completed.

9 System Parameter Setting

9.1 Bed Number

The Bed number can be set on the Setting- Bed number page.

9.2 Brightness

In the Setting- Brightness page, brightness of the display can be adjusted between 1 and 10 level by clicking "+" and "-" to set. After brightness setting is completed, click the "√" button to return to the previous page.

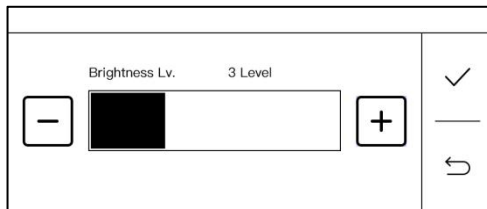

Figure 9-2 Brightness setting

9.3 Alarm Sound Volume

In the Setting- Volume- page, alarm sound volume can be

adjusted by clicking the "+" and "-" to set. After sound volume setting is completed, click the "√" button to return to the previous page.

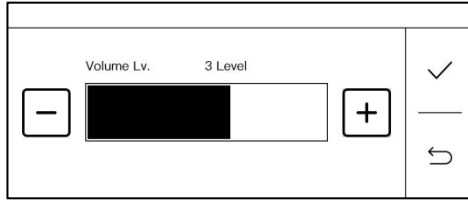

Figure 9-3 Alarm sound volume setting

9.4 Occlusion Pressure Level

The pressure threshold for occlusion alarm can be set on the System Settings-Occlusion Pressure Level page. Click + or – sign on the top of the screen to choose a pressure level. Click the "√" button to return to the previous page.

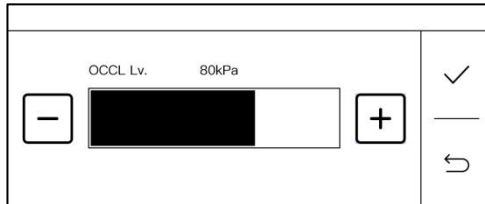

Figure 9-4 Occlusion pressure level setting

9.5 Air Bubble Detection Sensitivity

The Air-in-line detection sensitivity can be set the Home- Setting- Bubble page. Click on the "+" and "-" to adjust the sensitivity level. After setting is completed, click the "√" button to return to the previous page.

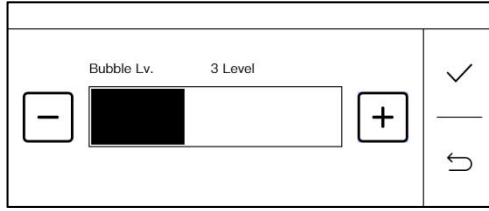

Figure 9-5 Air bubble detection sensitivity setting

The smaller the bubble level, the more sensitive it is. The minimum bubble size detectable for each level is shown in the following table:

Air Bubble Level	1	2	3	4	5	6	7	8	9
Bubble Size (μL)	25	50	100	200	300	500	800	1000	1200

9.6 Bolus Setting

The Bolus Rate and Bolus VTBI can be set on the Setting- Bolus page. Enter the corresponding parameter value to set. After the Settings are complete, click the Back button to return to the previous page.

9.7 Purge Setting

The Purge Rate and Purge VTBI can be set in Setting- Purge page. Enter the corresponding parameter value to set. The values set in the Purge setting will not affect the Bolus Rate and Bolus VTBI.

9.8 Call Back Time Setting

In the Setting- Call Back Time page, can set the Call Back Alarm

time when the device is placed without operation and not running.

9.9 KVO Setting

In the Setting - KVO page, set the KVO Mode and KVO Rate after the End Of Infusion.

Select the Constant KVO mode and the device will operate according to the currently set KVO Rate.

Select the Variable Speed KVO Mode, the device will automatically determine the KVO Rate level according to the current Infusion rate of the infusion operation, and run according to the KVO Rate of the currently set Infusion rate level.

Constant KVO Mode (V_{KVO} rate setting range: 0.10-5.00 mL/h, minimum step value 0.01 mL/h)

-When the infusion rate is $>V_{KVO}$: After the infusion task is completed, the pump automatically runs at the V_{KVO} rate to maintain venous patency.

-When the infusion rate is $\leq V_{KVO}$: After the infusion task is completed, the pump continues to run at the infusion rate to maintain venous patency.

Variable Speed KVO Mode (V_{KVO} rate setting range: 0.10-5.00 mL/h, minimum step value 0.01 mL/h)

Users need to set the V_{KVO} rate separately for three scenarios:

- (a) $V_{KVO}(>10)$ rate for infusion rates > 10 mL/h,
- (b) $V_{KVO}(1-10)$ rate for infusion rates between 1-10 mL/h, and
- (c) $V_{KVO}(\leq 1)$ rate for infusion rates ≤ 1 mL/h.

The system will automatically matches the KVO rate based on the infusion rate:

-When the infusion rate is > 10 mL/h: After the infusion task is completed, the pump automatically runs at the $V_{KVO}(>10)$ rate to maintain venous patency.

-When the infusion rate is between 1-10 mL/h: After the infusion task is completed, the pump automatically runs at the $V_{KVO}(1-10)$ rate to maintain venous patency.

-When the infusion rate is ≤ 1 mL/h and the infusion rate is $> V_{KVO}(\leq 1)$ rate: After the infusion task is completed, the pump continues to run at the $V_{KVO}(\leq 1)$ rate to maintain venous patency.

-When the infusion rate is ≤ 1 mL/h and the infusion rate is $\leq V_{KVO}(\leq 1)$ rate: After the infusion task is completed, the pump continues to run at the infusion rate to maintain venous patency.

9.10 Screen Lock Time

In the Setting- Auto Screen Lock page, set the Lock time for the screen and keys of the device during infusion operation.

If the screen lock time is set to 0, the Auto Screen Lock function is disabled.

You can also manually lock the device by clicking the "Lock screen" button on the screen when the device infusion is running. When the screen is locked, click the "Unlock" button on the screen to unlock it. When the screen is locked, other buttons and screen areas are unavailable except the power button and the Unlock button on the screen.

9.11 Near End of Infusion Time Setting

The near end of infusion time can be set on the Setting- Near

End of infusion page.

9.12 Prime Prompt Switch

On the Home- Setting- Prime prompt switch page, can choose whether to enable the Prime prompt, if this function is enabled, the "Prime" prompt page will appear when a new infusion task starts after each syringe change.

9.13 History Mode Switch

On the Home- Setting- History mode switch page, can choose whether to enable the History mode, if this function is enabled, the "Sure to load last treatment?" prompt page will be displayed after each power on.

9.14 IV Infusion Set Brand

The brand and type for the IV infusion set can be set on the System Settings-Brand page. Click on the check box on the right to choose IV infusion set brand. When completed, click on the Arrow button on the lower left corner to return to the previous page.

The selected brand for the IV infusion set will be shown on the infusion mode setting page, which can remind the operator to use the right IV infusion set to maintain high infusion accuracy.

Read Section 10.2 Calibration Steps for IV Infusion Set Accuracy for how to do calibration for an IV infusion set.

9.15 Night Mode Setting

On the System maintenance -Night mode page, set the brightness and sound parameter of the device during the night time

period. The setting method is the same as the setting of brightness and sound level.

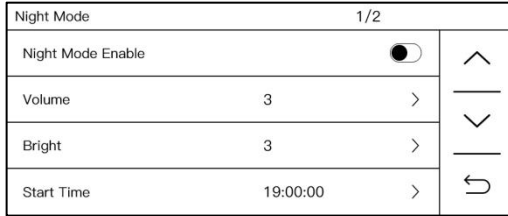

Figure 9-15 Night mode setting

9.16 Date/Time Setting

The device of Time and date can be set on the Maintenance-Date/Time page.

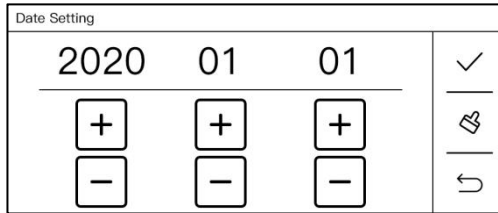

Figure 9-16-1 Date Setting

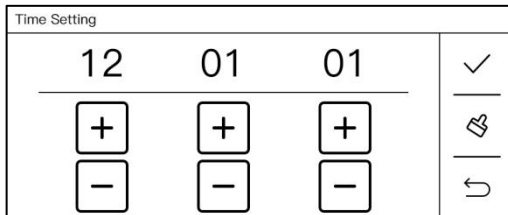

Figure 9-16-2 Time Setting

9.17 System Maintenance

System maintenance can be performed on the System Settings-Maintenance page, including the calibration of IV infusion set, system time setting, system language setting and etc.. A password is required to enter the system maintenance page. Contact the customer service at MDKMed for password assistance.

Read Section 10 in this manual for the procedure of performing calibration for IV infusion sets.

10 Accuracy Calibration for Infusion Set

If the brand or type of an IV infusion set has not been calibrated, or it is not from the same lot of IV infusion sets that have been calibrated, then calibration must be performed before use. Calibration of an already calibrated brand or type must be redone every six months.

10.1 Enter the Infusion set Accuracy Calibration Interface

The accuracy of the IV infusion set is calibrated in "Setting - System Maintenance - Consumables Maintenance - Calibration Consumables".

10.2 Accuracy Calibration for IV infusion set

- 1) Similar to performing a normal infusion operation, install the IV infusion set first, place the scalp needle into a measuring tube with scales. Enter the System Settings-System Maintenance - Calibration page.
- 2) Click on Brand to select the brand name. Return to the Calibration

page.

- 3) Click on High flow rate or Low flow rate to select the range of flow rate in which the calibration will be done. Return to the Calibration page. Please note that the range of flow rate should match the type of the scalp needle.
- 4) Press the Start/Stop key when at the Calibration page. The pump will stop after it has delivered a certain amount of liquid.
- 5) Place the beaker on the balance (the weight of the beaker has been removed), check the number of the balance, and convert it into the actual amount of solution, and enter the actual volume of solution in the Volume Output.
- 6) Click "√" at right to turn the page to the last page, click OK, the selection interface appears, select "√" to enter the save data waiting interface, wait for the saving to be completed and automatically return to the maintenance page; select "X" to return to the calibration page without saving the current consumable calibration data;
- 7) After the calibration is completed, return to the normal infusion to verify whether the accuracy of the IV infusion set is accurate.

11 Precautions for Using Disposable Consumables

It's suggested to use the recommended consumables. The ambient temperature should be kept at least at 10 °C or above when a recommended consumable is used. The infusion accuracy will be compromised if ambient temperature is lower than 10 °C.

The recommended consumables are listed in the table below:

No.	Brand	Model	Infusion accuracy	Ambient temperature
1	Hanaco	H-06APD-8	± 4.8%	+10 °C ~ +40 °C
2	JR	Automatic exhaust Regular With needle	± 4.8%	+10 °C ~ +40 °C
3	Kindly	Regular With needle	± 4.8%	+10 °C ~ +40 °C
4	Kangjin	IS-F-C3F	± 4.8%	+10 °C ~ +40 °C
5	Shinva	Regular With needle	± 4.8%	+10 °C ~ +40 °C
6	MDK	EF-BS1-P1	± 4.8%	+10 °C ~ +40 °C
7	Terumo	1TB*U800B	± 4.8%	+10 °C ~ +40 °C

The consumable used must have a medical device product registration certificate, and the consumable specifications are selected in the same specification as the recommended consumable brand. consumable Installation Methods See 7.3.1 Install/replace consumable.

In order to ensure infusion accuracy, when the ambient temperature changes significantly, the device needs to be re-calibrated, calibration method See Section 10 Accuracy Calibration for consumable.

Please strictly follow the requirements described in Section 10 to calibrate and use the consumable when change to a new consumable from a different manufacturer. Otherwise, the infusion accuracy may be compromised.

12 Technical Specifications

According to IEC60601-2-24 standard, we tested and obtained the

trumpet and flow rate graphs under the conditions of 1mL, 25mL, positive and negative back pressure, etc. The specific data are reflected in the IEC60601-2-24 test reports, and the relevant graphs will update in this section accordingly.

- 1) The methods of controlling Bolus volume before occlusion is removed: control Bolus volume by making the stepper motor to rotate in the opposite direction to reduce the pressure in infusion line after it has been occluded.
- 2) Storage time for the electronic memory after power off: same as the product lifetime.
- 3) The maximum volume that the pump can deliver under a single fault condition: 0.4 mL.
- 4) Unit used in device calibration: mL.
- 5) Minimum flow rate performance curve (1 mL/h)
 - a. The rising curve for HANACO IV infusion set with the minimum flow rate during the first 2 h of the test period.

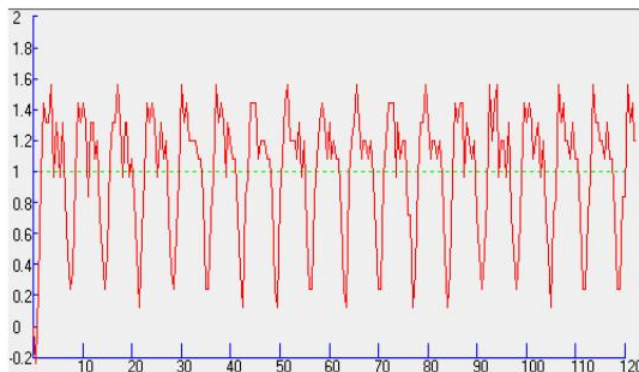

In the above figure, the dashed line shows the set flow rate (1 mL/h in this figure), and the solid line is the continuous connection

line for the average flow rate during a sampling period.

- b. The trumpet curve for HANACO IV infusion set with the minimum flow rate during the second hour of the test period.

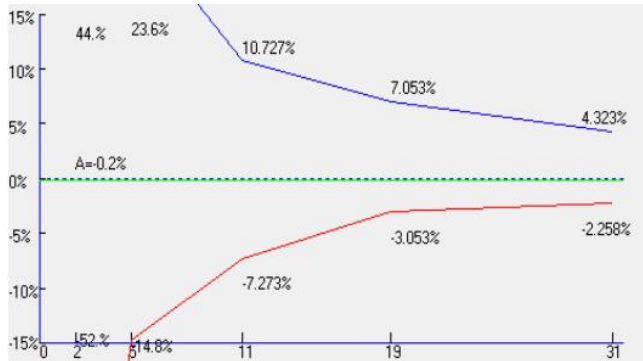

The dashed line in green color is the final value that the infusion error of the device is eventually converging to. The solid blue line above the dashed line is the maximum positive deviation during the second hour of the test period. The solid red line below the dashed line is the maximum negative deviation during the second hour of the test period.

- c. The trumpet curve for HANACO IV infusion set with the minimum flow rate during the last hour of the run.

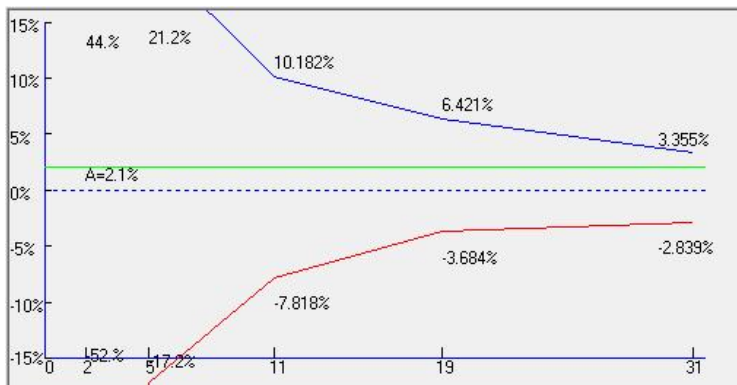

The green dashed line is the value where the device perfusion error finally converges. The solid blue line above the dashed line is the maximum positive deviation within the hour of the run. The solid red line below the dashed line is the maximum negative deviation within the last hour

- 6) Intermediate flow rate performance curve (25 mL/h)
 - a. The rising curve for HANACO IV infusion set with the intermediate flow rate during the first 2h of the test period.

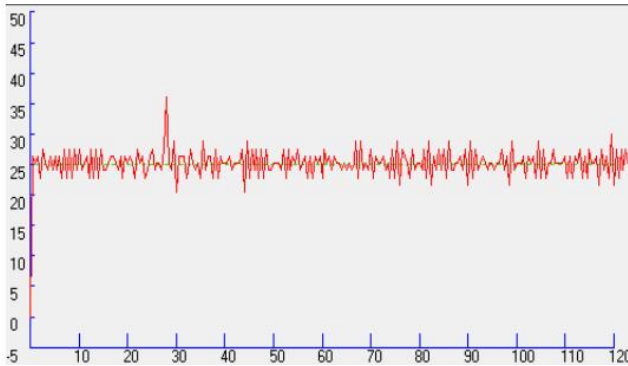

In the above figure, the dashed line shows the set flow rate (25 mL/h in this figure), and the solid line is the continuous connection line for the average flow rate during a sampling period.

- b. The trumpet curve for HANACO IV infusion set with the intermediate flow rate during the second hour of the test period.

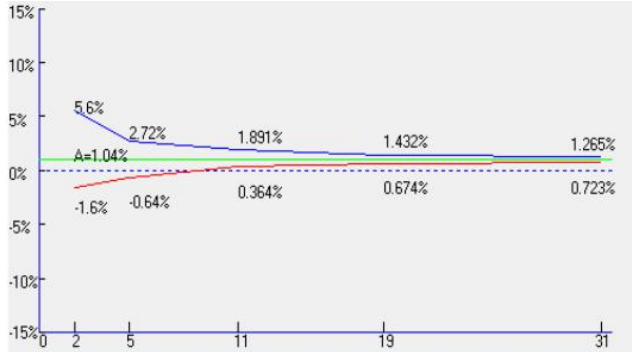

The dashed line in green color is the final value that the infusion error of the device is eventually converging to. The solid blue line above the dashed line is the maximum positive deviation during the second hour of the test period. The solid red line below the dashed line is the maximum negative deviation during the second hour of the test period.

- c. The trumpet curve for HANACO IV infusion set with the intermediate flow rate during the last hour of the run.

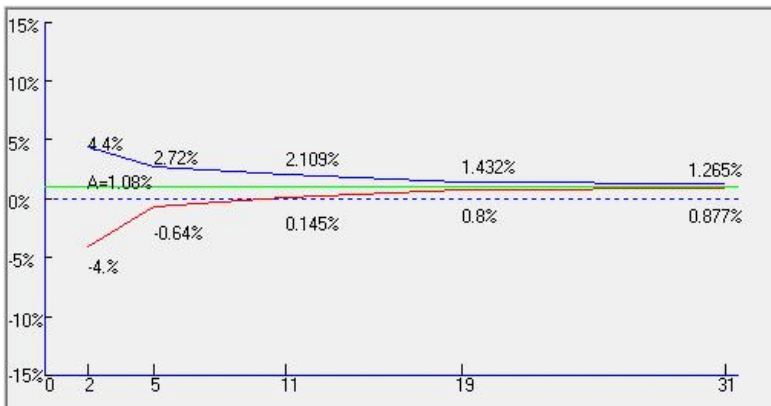

The green dashed line is the value where the device perfusion error finally converges. The solid blue line above the dashed line is the maximum positive deviation within the last hour of the run. The

solid red line below the dashed line is the maximum negative deviation within the last hour.

- 7) Intermediate flow rate and back pressure +13.3kPa performance curve
 - a. The rising curve for HANACO IV infusion set with the Intermediate flow rate and back pressure +13.3kPa during the first 2h of the test period.

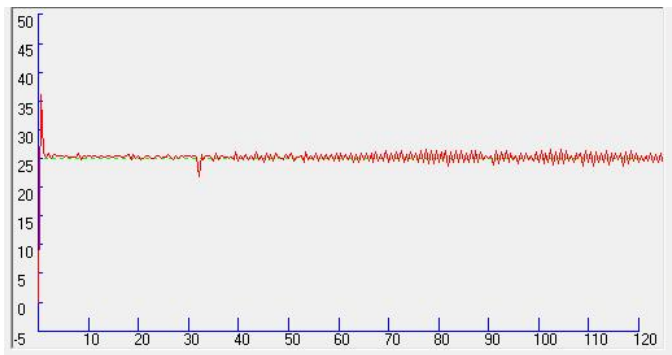

In the above figure, the dashed line shows the set flow rate (25 mL/h in this figure), and the solid line is the continuous connection line for the average flow rate during a sampling period.

- b. The trumpet curve for HANACO IV infusion set with the Intermediate flow rate and back pressure +13.3kPa during the second hour of the test period.

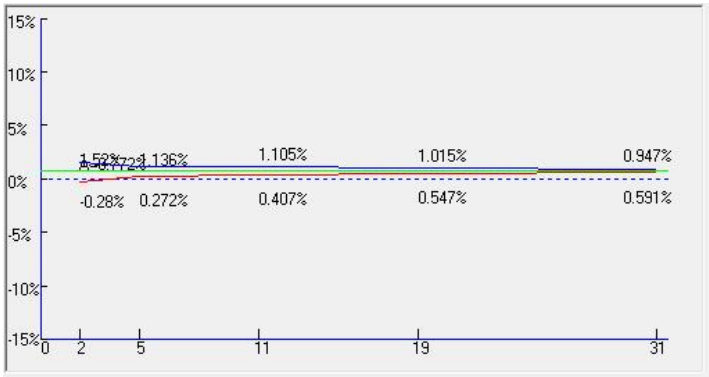

The dashed line in green color is the final value that the infusion error of the device is eventually converging to. The solid blue line above the dashed line is the maximum positive deviation during the second hour of the test period. The solid red line below the dashed line is the maximum negative deviation during the second hour of the test period.

8) Intermediate flow rate and back pressure -13.3kPa performance curve

- a. The rising curve for HANACO IV infusion set with the Intermediate flow rate and back pressure -13.3kPa during the first 2h of the test period.

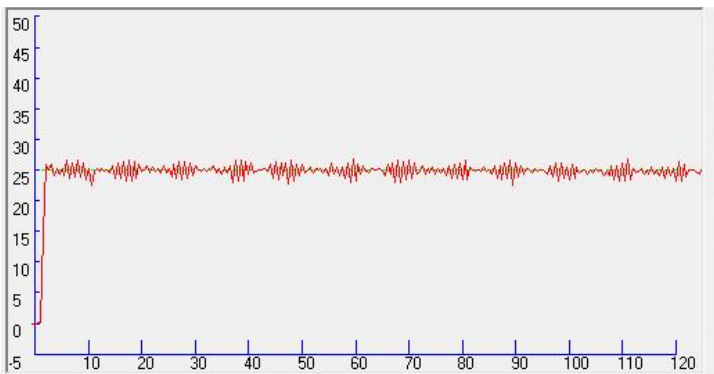

In the above figure, the dashed line shows the set flow rate (25 mL/h in this figure), and the solid line is the continuous connection line for the average flow rate during a sampling period.

- b. The trumpet curve for HANACO IV infusion set with the Intermediate flow rate and back pressure -13.3kPa the second hour of the test period.

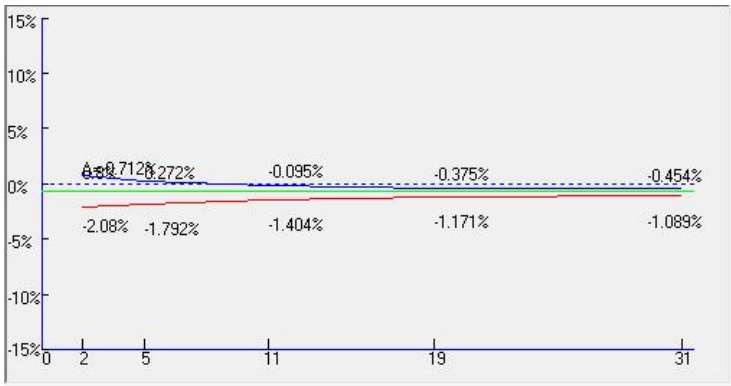

The dashed line in green color is the final value that the infusion error of the device is eventually converging to. The solid blue line above the dashed line is the maximum positive deviation during the second hour of the test period. The solid red line below the dashed line is the maximum negative deviation during the second hour of the test period.

- 9) Intermediate flow rate and below distance 0.5 meter performance curve

- a. The rising curve for HANACO IV infusion set with the Intermediate flow rate and the supply container below the pump mechanism at a distance of 0.5m during the first 2h of the test period.

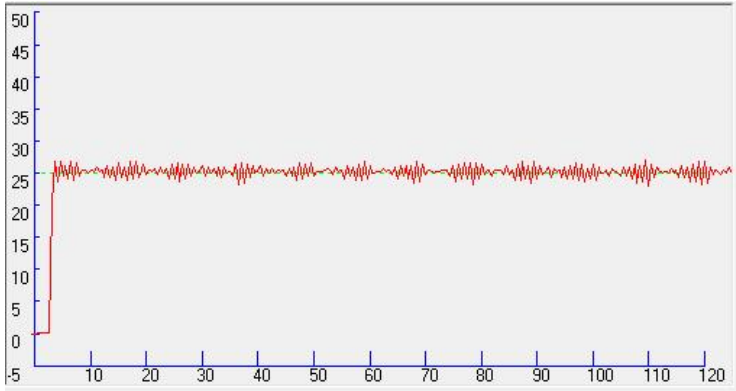

In the above figure, the dashed line shows the set flow rate (25 mL/h in this figure), and the solid line is the continuous connection line for the average flow rate during a sampling period.

- b. The trumpet curve for HANACO IV infusion set with the Intermediate flow rate and the supply container below the pump mechanism at a distance of 0.5m during the second hour of the test period.

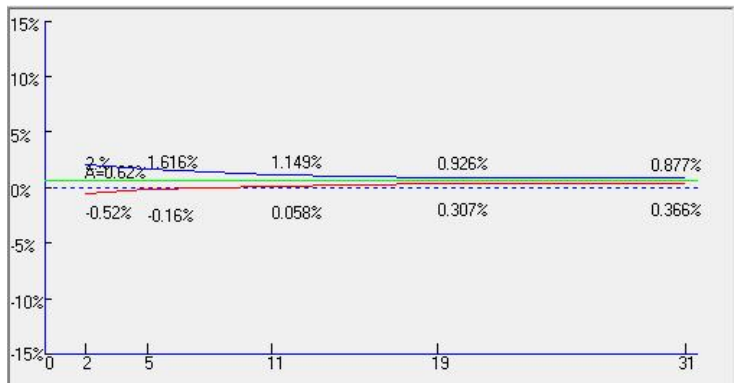

The dashed line in green color is the final value that the infusion error of the device is eventually converging to. The solid blue line above the dashed line is the maximum positive deviation during the second

hour of the test period. The solid red line below the dashed line is the maximum negative deviation during the second hour of the test period.

- 10) The sensitivity of the air-in-line sensor: the minimum air bubble size that can be detected is 25 μL .

13 Restore to Factory Setting

Default factory setting as below:

No.	Parameter	Default setting
1	Brightness level	Level 3
2	System sound level	Level 3
3	Bubble level	Level 3
4	Night mode sound level	Level 3
5	Night mode brightness level	Level 3
6	Occlusion pressure level	120 kPa
7	Night mode	Close
8	Infusion mode	Rate mode
9	KVO	Constant KVO
10	KVO rate	1.00 mL
11	Call back time	2 min
12	Near end of infusion time	5 min
13	Auto-lock	5 min
14	Night mode start	19:00:00
15	Night mode end	09:00:00
16	Bolus rate	1200.00 mL/h
17	Purge rate	1200.00 mL/h
18	Bolus volume	5.00 mL

19	Purge volume	15.00 mL
----	--------------	----------

14 Use, Maintenance and Uninstallation of the Internal Batteries

The MI27 Plus infusion pump has an internal rechargeable Lithium battery with the following specification: 21700/4800mAh*2PCS.

Daily maintenance of batteries:

- 1) When the pump is not used for a long period of time, the internal battery should be fully charged at least once for every 3 months by connecting the device to the mains power to help saving the battery life.
- 2) Contact the customer service at MDKMed immediately if the internal battery cannot be charged or cannot work normally. Do not tamper with the battery. For the healthcare providers who have the ability to repair a device, MDKMed will provide training to the related personnel from these facilities. Then a device can be disassembled and the battery can be changed at these facilities.

The device has a internal disposable coin cell battery designed to last longer than 8 years, when the set time is exceeded, need to be disposed with the device in accordance with the instructions for waste disposal in this manual 16.

15 Service and Maintenance

Inspect the pump before use:

- 1) Check if there are foreign objects inside the power outlet (such as drug solution residue). Confirm that the system has passed the

self-test after the pump is powered on.

- 2) Select the correct type for IV infusion set. Check the battery level. Charge the battery if necessary.

During operation:

- 1) To avoid giving an incorrect dosage of drug to a patient, disconnect the pump from the patient before changing a device.
- 2) Please make sure that the infusion line is not kinked. Insert the needle to the vein on a part of the patient's body where it is not likely to be squeezed or pressed.
- 3) To prevent the spilled drug solution on the pump surface from getting into the inside of the device, wipe it dry immediately if there is a spill.

Storage and daily maintenance:

- 1) To keep the device clean, wipe it clean for at least once a month, which can prevent the corrosion caused by the drug solution and avoid the mobility of the mechanical parts being affected by the dried solution.
- 2) Use a clean and dampened cloth or an alcohol pad to wipe clean the device. Take caution to avoid any liquid from entering the device.
- 3) Keep the surface of the air bubble sensor probe clean. A dirty probe will reduce the sensor's sensitivity in air bubble detection or cause false alarm. Take caution when cleaning the probe to avoid causing any damage.

Disinfection method:

If disinfection is required, commonly used disinfectants can be used. After using the disinfectant, after wetting with a soft cloth in

water, wring out the soft cloth for scrub treatment. When using disinfectants, follow their instructions.

16 Waste Disposal

16.1 Battery

Follow the local laws and regulations to dispose the expired old battery.

16.2 IV Infusion Set

Follow the local laws and regulations to dispose the IV infusion set after use.

16.3 Infusion Pump

The product lifetime of this device is 8 years. Dispose the device after its lifetime has expired. The disposed infusion pump can be returned to MDKMed or its distributors to be properly recycled.

17 Electromagnetic Compatibility

Precautions regarding electromagnetic compatibility (EMC) shall be taken when this device is used. The installation and operation of this device must follow the EMC requirements specified in this guide.

Portable and mobile RF communication device may affect this device.

Use only the cables and accessories provided with this device.

The cable information is as below:

Cable Name	Length
DC Power adapter	2.9 m

Using cables that are other than the ones provided with the device may lead to increased electromagnetic emission and to reduced immunity to external electromagnetic interference. To ensure safe operation of this pump, do not stack the pump with other device that has electromagnetic emission. Monitor the operation of the device, if it has to be used in close proximity or it has to be stacked with such device. The basic performance of the device is based on the operation when it is connected to the mains power (including the internal battery).

Name	Specific Description
Mains power connection and operation (including internal battery)	The infusion accuracy is within $\pm 4.8\%$ when the device is in normal operation at an intermediate rate of 25 mL/h and a total volume ≥ 10 mL, if no abnormality or error occurs during the operation.

Note: The emissions characteristics of this device make it suitable for use in industrial areas and hospitals (CISPR 11 class A). If it is used in residential environment (for which CISPR 11 class B is normally required) this device might not offer adequate protection to radio-frequency communication services. The user might need to take mitigation measures, such as relocating or re-orienting the device.

**Guidance and MANUFACTURER’S declaration –
ELECTROMAGNETIC EMISSIONS – for all ME device and ME
SYSTEMS**

Guidance and manufacture’s declaration – electromagnetic emission	
The infusion pump MI27 Plus is intended for use in the electromagnetic environment specified below. The customer or the user of the infusion pump MI27 Plus should assure that it is used in such and environment.	
Emissions test	Compliance
RF emissions CISPR 11	Group 1
RF emissions CISPR 11	Class A
Harmonic emissions IEC 61000-3-2	Not applicable
Voltage fluctuations / flicker emissions IEC 61000-3-3	Not applicable

**Guidance and MANUFACTURER’S declaration – electromagnetic
IMMUNITY – for all ME device and ME SYSTEMS**

Guidance and manufacture’s declaration – electromagnetic immunity		
The infusion pump MI27 Plus is intended for use in the electromagnetic environment specified below. The customer or the user of infusion pump MI27 Plus should assure that it is used in such an environment.		
Immunity test	IEC 60601 test level	IEC 60601 test level
Electrostatic discharge (ESD) IEC 61000-4-2	±8 kV contact ±15 kV air	±8 kV contact ±15 kV air
Electrical fast transient/burst IEC 61000-4-4	±2 kV for power supply lines ±1 kV signal input/output	±2 kV for power supply lines Not Applicable
Surge IEC 61000-4-5	±1 kV differential mode ±2 kV common mode	±1 kV differential mode Not applicable

Voltage dips, short interruptions and voltage variations on power supply input lines IEC 61000-4-11	0 % UT; 0,5 cycle At 0°, 45°, 90°, 135°, 180°, 225°, 270° and 315°. 0 % UT; 1 cycle and 70 % UT; 25/30 cycles; Single phase: at 0°. 0% UT; 250/300 cycle	0 % UT; 0,5 cycle At 0°, 45°, 90°, 135°, 180°, 225°, 270° and 315°. 0 % UT; 1 cycle and 70 % UT; 25/30 cycles; Single phase: at 0°. 0 % UT; 250/300 cycle
Power frequency (50/60Hz) magnetic field IEC 61000-4-8	30 A/m 50Hz/60Hz	30 A/m 50Hz/60Hz
Note: UT is the a.c. mains voltage prior to application of the test level.		

Guidance and MANUFACTURER’S declaration – electromagnetic IMMUNITY –for ME device and ME SYSTEMS that are not LIFE-SUPPORTING

Guidance and manufacture’s declaration – electromagnetic immunity		
The Infusion pump MI27 Plus is intended for use in the electromagnetic environment specified below. The customer or the user of Infusion pump MI27 Plus should assure that it is used in such an environment.		
Immunity test	IEC 60601 test level	Compliance level
Conducted RF IEC61000-4-6	3 V 0,15 MHz – 80 MHz 6 V in ISM bands between 0,15 MHz and 80 MHz	3 V 0,15 MHz – 80 MHz 6 V in ISM bands between 0,15 MHz and 80 MHz
Radiated RF IEC61000-4-3	3 V/m 80 MHz – 2,7 GHz	3 V/m 80 MHz – 2,7 GHz
NOTE 1 At 80 MHz and 800 MHz, the higher frequency range applies.		
NOTE 2 These guidelines may not apply in all situations. Electromagnetic propagation is affected by absorption and reflection from structures, objects and people.		

^a Field strengths from fixed transmitters, such as base stations for radio (cellular/cordless) telephones and land mobile radios, amateur radio, AM and FM radio broadcast and TV broadcast cannot be predicted theoretically with accuracy. To assess the electromagnetic environment due to fixed RF transmitters, an electromagnetic site survey should be considered. If the measured field strength in the location in which the Infusion pump is used exceeds the applicable RF compliance level above, the Infusion pump should be observed to verify normal operation. If abnormal performance is observed, additional measures may be necessary, such as reorienting or relocating the Infusion pump MI27 Plus.

^b Over the frequency range 150 kHz to 80 MHz, field strengths should be less than 3 V/m.

Guidance and manufacturer’s declaration - electromagnetic Immunity

The Infusion pump MI27 Plus is intended for use in the electromagnetic environment specified below. The customer or the user of the Infusion pump MI27 Plus should assure that it is used in such an environment

Radiate d RF	Test Frequen cy (MHz)	Band a) (MHz)	Service a)	Modulati on b)	Modul ation b) (W)	Distanc e (m)	IMMUNI T Y TEST LEVEL (V/m)
IEC6100 0-4-3 (Test specifica tions for ENCLO SURE PORT IMMUNI TY to RF	385	380 –390	TETRA 400	Pulse modulati on b) 18 Hz	1,8	0,3	27
	450	430 –470	GMRS 460, FRS 460	FM ± 5 kHz deviatio	2	0,3	28

wireless communica- tions device)				n b) 1 kHz sine			
	710	704 – 787	LTE Band 13, 17	Pulse modulati on b) 217 Hz	0,2	0,3	9
	745						
	780						
	810	800 – 960	GSM 800/900, TETRA 800, iDEN 820, CDMA 850, LTE Band 5	Pulse modulati on b) 18 Hz	2	0,3	28
	870						
	930						
	1720	1700 – 1990	GSM 1800; CDMA 1900; GSM 1900; DECT; LTE Band 1, 3, 4, 25;	Pulse modulati on b) 217 Hz	2	0,3	28
	1845						
	1970						

			UMTS				
	2450	2 400 – 2 570	Bluetooth, WLAN, 802.11 b/g/n, RFID 2450, LTE Band 7	Pulse modulation on b) 217 Hz	2	0,3	28
	5240	5 100 –	WLAN	Pulse	0,2	0,3	9
	5240	5 800	802.11	modulation			
	5785		a/n	on b) 217 Hz			

NOTE If necessary to achieve the IMMUNITY TEST LEVEL, the distance between the transmitting antenna and the ME device or ME SYSTEM may be reduced to 1 m. The 1 m test distance is permitted by IEC 61000-4-3.

- a) For some services, only the uplink frequencies are included.
- b) The carrier shall be modulated using a 50 % duty cycle square wave signal.
- c) As an alternative to FM modulation, 50 % pulse modulation at 18 Hz may be used because while it does not represent actual modulation, it would be worst case.

The MANUFACTURER should consider reducing the minimum separation distance, based on RISK MANAGEMENT, and using higher IMMUNITY TEST LEVELS that are appropriate for the reduced minimum separation distance. Minimum separation distances for higher IMMUNITY TEST LEVELS shall be calculated using the following equation:

$$E = \frac{6}{d} \sqrt{P}$$

Where P is the maximum power in W, d is the minimum separation distance in m, and E is the IMMUNITY TEST LEVEL in V/m.

Guidance and manufacturer’s declaration - electromagnetic Immunity

The Infusion pump MI27 Plus is intended for use in the electromagnetic environment specified below. The customer or the user of the Infusion pump MI27 Plus should assure that it is used in such an environment

Radiated fields in close proximity	Test Frequency	Modulation	IMMUNITY Test Level (A/m)
IEC61000-4-39	30 kHz	CW	8
(Test specifications for ENCLOSURE PORT	134.2 kHz	Pulse modulation 2.1 kHz	65
IMMUNITY to proximity magnetic fields)	13.56 MHz	Pulse modulation 50 kHz	7,5

18 Antistatic Precautions

The MI27 Plus infusion pump has been tested and is compliant with Medical device Standard IEC60601-1-8.

When used by an operator, the pump should not be contacted with connector pins that have electrostatic discharge warning signs. Unless electrostatic discharge prevention measures are taken, the pump should not be contacted with these connectors.

The operator should be aware of the following things:

A) Unless appropriate preventive measures have already been taken, do not use hand or hand tool to touch connectors with electrostatic discharge warning signs. Preventive measures include:

1. Methods for preventing electrostatic charge accumulation (such as air conditioning, air humidification, floor conductive coating or synthetic clothing);
2. Discharge electrostatic charge from human body to the framework of device, or to the ground, or to a large piece of metal;
3. Use a wrist band to connect human body to the device or to the ground.

B) All staff who may be in contact with connectors with electrostatic discharge warning signs should receive training, including all clinical/biomedical engineering and healthcare personnel.

C) Electrostatic discharge training should include the introduction of static charges in the theory of physics, the voltage that may be produced in normal practice, and the damage to the electronic components caused by the electrostatic charge from an operator. Further, methods for how to prevent electrostatic charge accumulation should be provided, as well as how and why to discharge the electrostatic from human body to the framework of device or to the ground, and how to use wrist band to connect someone's body to the device or to the ground.

19 Packaging and Accessories

The recommended accessories to be used with the device (per unit):

Accessory Name	Quantity	Unit
User Manual	1	Book
DC Power Adapter	1	Set
Refer to the packing list for all other accessories.		



Legal manufacturer: MDKMed Medical Technology Co., Ltd.

Address: 502A, Building 7, No. 22, Xinyan Road, Donghu Street,
Linping District, Hangzhou City, Zhejiang Province, P. R China 311323

After sale service: MDKMed Medical Technology Co., Ltd.

Tel: 400-880-8392

Email: sales@graseby.com

Web: <http://www.graseby.com>

Revision date: 02-01-2025

Part No.: 07.01.0166A



European Authorized Representative:

MedNet EC-REP C IIb GmbH

Borkstrasse 10

48163 Münster, Germany