

Graseby V20 CC Infusion Pump User Manual

Version: 1.3

MDKMed Medical Technology Co., Ltd.
2025.3.13

Content

1 Symbols, Graphics and Warnings	6
1.1 Descriptions of Graphics and Symbols	6
1.2 Warning	7
2 Terms and Definitions	14
3 Brief Introduction and Scope of Application	14
3.1 Brief Introduction	14
3.2 Intended Purpose	15
3.3 Model Naming	15
3.4 Benefits	16
4 Important Features	16
5 Specifications	18
5.1 Basic Specifications	18
5.2 Main Performance	18
5.3 Main Functions and Common Functions	22
6 Structure and Operation Interface	23
6.1 Structural Composition	23
6.2 Display and Operation Interface	28
7 Operation Instructions	29
7.1 Installation of Infusion Pump	29
7.2 Power on and Device Safety Self-test	29
7.2.1 Power on and off	29
7.2.2 Device Safety Self-test	30
7.3 Quick Use Guide	30
7.3.1 Install / Replace IV infusion set	30
7.3.2 Select IV infusion set	31

7.3.3 Install Drop Sensor (optional)	32
7.3.4 Install CC pressure disc	33
7.3.5 Set Infusion Parameters	34
7.3.6 Purge	35
7.3.7 Start Infusion	36
7.3.8 Infusion Completed	37
7.4 Pause or Stop Infusion	37
7.5 Bolus	38
7.6 Lock and Unlock Screen Function	39
7.7 Infusion Mode Selection and Setting	39
7.7.1 Dose Mode	40
7.7.2 Drug Library Mode	41
7.7.3 Drop Speed Mode	42
7.7.4 RTM Mode	42
7.7.5 Sequence Mode	43
7.7.6 Loading Dose Mode	44
7.7.7 Intermittent Mode	45
7.7.8 Micro Mode	46
7.7.9 Relay Mode	47
7.7.10 TIVA mode	47
7.7.11 Piggyback Mode	48
7.7.12 Feeding Mode	50
7.7.13 Transfusion Mode	51
7.8 Rate Locking Function	52
7.9 CC Setup	54
7.9.1 CC Auto Set Pressure	54
7.9.2 CC Pressure Alarm Threshold	55
7.9.3 CC Pressure Level Chart	56











7.10 View Log	57
8 Alarms	58
8.1 Door Open Alarm	62
8.2 IV-Set Setup Fail Alarm	63
8.3 Occlusion Alarm	63
8.4 Upstream Occlusion Alarm	64
8.5 End of Infusion Alarm	65
8.6 Air-in-line Alarm	65
8.7 Battery Empty Alarm	66
8.8 Battery & External Power Disconnect Alarm	66
8.9 Motor Error Alarm	67
8.10 Communication Error Alarm	67
8.11 Battery Error Alarm	68
8.12 KVO Alarm	68
8.13 KVO End Alarm	69
8.14 Standby End Alarm	69
8.15 No AC Power Alarm	69
8.16 Call Back Alarm	70
8.17 Low Battery Alarm	70
8.18 Near End of Infusion Alarm	70
8.19 Drip Rate Error Alarm	71
8.20 CC Line Occlusion Alarm	71
8.21 CC Pressure Disc Out Alarm	72
8.22 Needle Fall off Alarm	72
9 System Parameter setting	72
9.1 Bed Number	72
9.2 Brightness	72
9.3 Alarm Sound Volume	72



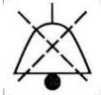

9.4 Occlusion Pressure Level	73
9.5 Air Bubble Detection Sensitivity	73
9.6 Bolus Setting	73
9.7 Purge Setting	74
9.8 Call Back Time Setting	74
9.9 KVO Setting	74
9.10 Screen Lock Time	74
9.11 Near End of Infusion Time Setting	76
9.12 Prime Prompt Switch	76
9.13 History Mode Switch	76
9.14 IV Set Brand	77
9.15 Night Mode Setting	77
9.16 Date/Time Setting	78
9.17 Maintenance	78
10 Calibration	78
10.1 Accuracy Calibration for IV infusion set	79
10.1.1 Enter infusion set accuracy calibration interface	79
10.1.2 Accuracy Calibration for IV infusion set	79
10.2 CC Calibration	80
10.2.1 Calibration tool	80
10.2.2 Calibration steps	80
11 Precautions for Using Disposable Consumables	80
12 Technical Specification	81
13 Restore to Factory Setting	89
14 Use, Maintenance and Removal of the Internal Battery	90
15 Service and Maintenance	91
16 Waste Disposal	92
16.1 Battery	92

16.2 IV infusion set	92
16.3 Infusion pump	92
17 Electromagnetic Compatibility	93
18 Antistatic Precautions	99
19 Packaging and Accessories	100

1 Symbols, Graphics and Warnings

1.1 Descriptions of Graphics and Symbols

	Caution		Read the User Manual
	Defibrillation prevention Type CF device	RoHS	Compliant to RoHS standards
	Date of manufacturing		Class II device
	Serial Number		Classified collection, uncontrolled discard not allowed
IP44	Ingress Protection Grade	~	AC (Alternating Current)
	DC (Direct current)		Non-ionizing electromagnetic radiation
	Mute		Lithium battery

	<p>European Representative</p>		<p>Manufacturer</p>
	<p>CE mark demonstrating compliance with RoHS and other EU directives</p>		<p>Medical device marking</p>

1.2 Warning

Please read the following information carefully, operation that does not strictly follow the guidance will possibly damage the device or do harm to patients' health.

- 1) The infusion pumps are intended to intermittently or continuously delivery the parenteral fluids, medications, blood and blood products via IV infusion route, delivery enteral fluids via the alimentary canal or any route connected to the gastrointestinal system (i.e., the enteral route). The devices can be used together with liquid storage devices /IV infusion sets /Blood transfusion sets /Enteral feeding sets. /Enteral feeding sets.
- 2) Untrained personnel are not allowed to operate the device. The operator must carefully read this User's Manual, so as to prevent medical accidents caused by improper operation
- 3) To prevent fire or explosion, it is forbidden to use this device in an environment where flammable or explosive matters are present.
- 4) Do not stack and use other devices that may generate external radio frequency interference or electromagnetic radiation that may

affect the safe operation of this device.

- 5) The operator must use the recommended IV infusion set calibrated in accordance with the requirements described in Section 10 Accuracy Calibration for IV infusion set in this guide, and ensure that the correct IV infusion set brand and type are selected.
- 6) The IV infusion set that is not recommended should never be used for infusion, otherwise it may lead to large infusion inaccuracy and even to become unusable.
- 7) The installation height of this device should not be more than 1 meter above or below the patient's heart.
- 8) It is forbidden to reuse the same IV infusion set on another infusion device.
- 9) This device cannot be used as a portable device.
- 10) It is forbidden to use sharp objects to press on the buttons or the touch screen.
- 11) The Infusion Pump must be serviced and calibrated by trained professional technicians. Before maintenance, make sure to unplug the power cable that supplies power to the device. Untrained personnel are strictly prohibited from opening the device casing, otherwise the eligibility for warranty of the device will be lost.
- 12) Please make sure to use only the parts and accessories provided by MDK.
- 13) When hit hard or dropped, the pump should not be used until it has been checked by trained technical staff.
- 14) Except for wiping the outer surface of the device according to Section 15 Service and Maintenance in this manual, no other part of the device shall be serviced or maintained by users. If there is

any abnormality in the device, please contact the customer service of MDK.

- 15) During the use of the device, the device should be placed smoothly and fixed firmly.
- 16) After loading the IV infusion set, the operator is required to check whether the liquid medicine in the IV infusion set leaks. If there is leakage, stop using the IV infusion set and notify the customer service of MDK.
- 17) Operator should set the infusion parameters strictly based on the doctor's prescriptions. Mistakes in infusion parameter settings may cause harm to patients.
- 18) After setting infusion parameters, the operator must ensure that the infusion set is properly stuck to the device before starting infusion.
- 19) In order to maintain a high infusion accuracy, the contacting spot of compression on an IV infusion set should be changed every 8 hours. When the MDK IV infusion set is used, the IV infusion set should be changed every 48 hours to maintain a high accuracy of infusion.
- 20) To maintain high infusion accuracy, the pump needs to be re-calibrated when there is a significant change in ambient temperature.
- 21) The pump will stop operation automatically when there is an alarm. Press the Start-Stop key or click the start button to resume operation after the alarm causing condition is removed.
- 22) To avoid failure or false alarm caused by a dirty occlusion sensor or air- in-line sensor, operator should wipe clean the pump on a regular basis to keep it clean.

- 23) If the sound pressure level of the audible alarm is less than the environmental noise, the operator should turn the alarm volume up to ensure the alarm sound can be heard.
- 24) Pump or accessories may not be usable if their lifetime for use has expired (the lifetime for pump is 8 years). Contact MDK to upgrade to new products.
- 25) The device has a internal rechargeable lithium battery and its lifetime is 2 years.
- 26) Please check the voltage of the internal battery before using it for pump operation. The battery must be replaced and maintained by trained technical personnel in accordance with Section 14 Use, Maintenance and Removal of the Internal Battery in this manual. Replacing the battery by personnel without sufficient training will lead to risks such as over temperature, fire or explosion.
- 27) Please do not connect any other device to the USB and type-c port other than the included DC power adapter shipped with the pump.
- 28) For different types of patients, different occlusion alarm pressure threshold should be set, please refer to the doctor's advice for details.
- 29) Healthcare professional should check on the device during operation on a regular basis, and he/she should also pay attention to medication solution in the IV infusion set before starting the device to make sure the right medicine is in the right infusion channel.
- 30) Please use the roller clamp and other components on the IV infusion set correctly based on the corresponding instruction of the consumable per sec.

- 31) When using this device, please do not plug the power to somewhere that is difficult to plug or unplug. Use an independent power outlet as a measure in case quick disconnection is needed.
- 32) IV infusion set needle is the application part of this product.
- 33) While in normal operation, an alarm will be triggered if the pump door is opened. Please contact MDK for service if this alarm fails to appear.
- 34) If the sticker on the screw hole is removed, then consider the fact that the pump has been tampered with, and discontinue use.
- 35) The product is not AP or APG type device and should not be used in flammable gas environment.
- 36) Don't near active HF SURGICAL device and the RF shielded room of an ME SYSTEM for magnetic resonance imaging, where the intensity of EM DISTURBANCES is high.
- 37) Use of this device adjacent to or stacked with other device should be avoided because it could result in improper operation. If such use is necessary, this device and the other device should be observed to verify that they are operating normally.
- 38) Use of accessories, transducers and cables other than those specified or provided by the manufacturer of this device could result in increased electromagnetic emissions or decreased electromagnetic immunity of this device and result in improper operation.
- 39) Portable RF communications device (including peripherals such as antenna cables and external antennas) should be used no closer than 30 cm (12 inches) to any part of the Graseby V20 CC, including cables specified by the manufacturer. Otherwise,

degradation of the performance of this device could result.

- 40) The EMISSIONS characteristics of this device make it suitable for use in industrial areas and hospitals (CISPR 11 class A). If it is used in a residential environment (for which CISPR 11 class B is normally required) this device might not offer adequate protection to radio-frequency communication services. The user might need to take mitigation measures, such as relocating or reorienting the device.
- 41) The ME device or ME SYSTEM is suitable for professional healthcare facility environments.
- 42) If the device needs to be used on the move (transport within the hospital): make sure the device is securely fixed and placed. If the device is changed in position, or the pump is severely shaken, the accuracy of the infusion may be affected.
- 43) Do not use unapproved cleaners, materials or chemicals as they may damage device surfaces, labels, or cause device failures.
- 44) Do not route LVP supply bag or administration set right above the pump.
- 45) Do not route the administration set in a way that presents tripping hazard and administration set break off.
- 46) Do not change the height of pump during infusion, otherwise the infusion accuracy may be affected.
- 47) For different types of patients, different occlusion pressure Level should be set. For details, please refer to the doctor's advice.
- 48) When the device is powered by the internal battery, the charging indicator light is blue; When the device is powered through the net power supply, the external power indicator light will turn green. At

this time, if the battery is not fully charged, the charging indicator light will turn green at the same time, and the charging indicator light will not turn on when the battery is fully charged.

- 49) Any serious incident that has occurred in relation to the device should be reported to the manufacturer and the competent authority of the Member State in which the user and/or patient is established.
- 50) Do not modify this equipment without authorization of the manufacturer.
- 51) If this equipment is modified, appropriate inspection and testing must be conducted to ensure continued safe use of the equipment.
- 52) If necessary, please contact the company's customer service staff to provide the relevant information of maintenance.
- 53) To remove or insert a CC pressure disc from or into CC pressure transducer assembly, insert finger into the recess in the CC pressure disc and pull forward or push back carefully. Do not pull the infusion tube to remove or to insert the CC pressure disc.
- 54) CC pressure transducer: Fully Dedicated - to start an infusion, a CC pressure disc must be fitted; Semi Dedicated - to start an infusion with DRUG NAME or DOSING ONLY selected, a CC pressure disc must be fitted.
- 55) When using a CC pressure disc, you should prime the infusion line before installing the disc to the CC pressure transducer. If you need to prime the infusion line after installing the CC pressure disc, the disc must be removed before priming and reinserted after priming.
- 56) To purge the infusion line, massaging the CC pressure disc to prevent ballooning and ensuring all air removal.

2 Terms and Definitions

Operator: A professionally trained and qualified member of medical staff.

Keep vein open (KVO): After infusion is completed based on the preset parameters, the pump will automatically switch to a mode with extremely low Infusion rate and continue to run (this mode virtually does not have any treatment effect), which is to keep the IV infusion set and vein unobstructed and to avoid the blood flowing backwards.

Intermediate rate: An Infusion rate of 25.00 mL/h.

Minimum rate: An Infusion rate of 1.00 mL/h.

Free-flow: Drug solution is flowing out in an uncontrolled manner under the effect of gravity.

VTBI: Volume to be infusion.

Piggyback: Piggyback infusion.

CC: short for Critical Care, specifically referring to the sensitive detection function of 1mmHg pressure changes that our company's CC sensor and dedicated infusion line have.

3 Brief Introduction and Scope of Application

3.1 Brief Introduction

Graseby V20 CC(hereinafter referred to as V20 CC) is a kind of infusion device, it is mainly consisted of pump housing, motor drive system, input system, storage system, control system, display system, sensor monitoring system, alarm system and power system (adapter).

3.2 Intended Purpose

Intended Use: The infusion pumps are intended to intermittently or continuously delivery the parenteral fluids, medications, blood and blood products via IV infusion route, delivery enteral fluids via the alimentary canal or any route connected to the gastrointestinal system (i.e., the enteral route). The devices can be used together with liquid storage devices /IV infusion sets /Blood transfusion sets /Enteral feeding sets. /Enteral feeding sets.

Indication for use: N/A.

Contraindications: None.

Intended patient population: The target population is adults, pediatrics (including newborns) who need intravenous therapy, blood transfusion and enteral nutrition, no other specific requirements.

Intended users of the device: The device is intended to be used by trained healthcare professionals in medical institution environments.

3.3 Model Naming

GrasebyV20CC

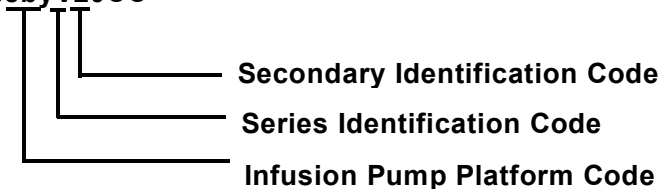

3.4 Benefits

Since the infusion pumps do not come into contact with patient directly, they don't have direct clinical benefit to patients. So the clinical benefit of the infusion pump is that the device enables the precisely administration of intravenous fluid /blood /blood product /enteral fluid procedure to be undertaken, and realizes the monitoring of the infusion processing (the device is able to send alarms during infusion process when occlusion or other circumstances), which can greatly increase the infusion safety.

4 Important Features

- 1) **Accuracy:** The accuracy for infusion rate and volume both are kept within 4%.
- 2) **Flow rate:** The Infusion rate can be adjusted from 0.01 mL/h to 2000.00 mL/h in a continuous manner, which makes the infusion pump capable of meeting various flow rate requirements in different infusion situations.
- 3) **External power supply:** An external power adapter is used, which not only removes the safety concerns of using an internal switching power source but also makes the device lighter and smaller in size.
- 4) **Battery capacity:** The rechargeable internal high-capacity Lithium battery can support normal operation for about 6 hours, which is conveniently helpful during patient transport or power outage.
- 5) **Display:** LCD touch screen display offers high contrast, great visibility and user friendly usability.
- 6) **Occlusion Alarm:** Both upstream and downstream occlusion alarms are available.

- 7) **Air-in-line alarm:** Based on ultrasonic technology, the device is capable of detecting air bubble sizes down to 25 μ L and initiating air-in-line alarm.
- 8) **Real-time pressure monitoring:** The Graseby V20 CC infusion pump can monitor the dynamic pressure value of the patient during the entire infusion process in real time, ranging from 25-1000mmHg to 1mmHg ($\text{kPa} \times 7.5 = \text{mmHg}$, $\text{mmHg} \times 0.133 = \text{kPa}$).
- 9) **Dynamic pressure display:** The Graseby V20 CC infusion pump displays dynamic pressure curves, helping nurses detect complications in the infusion site as soon as possible, such as extravasation of medication and infusion line blockage. So as to protect patient safety and ensure the infusion accuracy.
- 10) **Reduce bolus after occlusion:** The CC pressure sensor accurately and sensitively detects infusion line pressure and intelligently alarms, significantly reducing the delay time of occlusion alarm and reducing bolus caused by the occlusion compared to conventional infusion pumps.
- 11) **Auto Set Pressure:** The traditional threshold for occlusion pressure alarm is an absolute value, while the dynamic changes in intravascular pressure can intelligently determine whether there is a possibility of blockage based on the trend of relative changes in pressure from a steady-state value. This device prompts medical staff to handle it in a timely manner to avoid occlusion and the occurrence of bolus after occlusion.
- 12) **Needle fall off:** Through real-time detection of CC pressure, it was found that the needle had fallen off and the nurse will be prompted to handle it to avoid contamination and insufficient infusion.

- 13) **Rate locking:** For special drugs and specific infusion scenarios, medical staff can choose to limit the flow rate during operation to avoid occlusion alarms caused by drastic changes in flow rate, e.g.: sudden changes in blood drug concentration, etc.
- 14) **Back off (Anti Bolus):** Prevent accidental bolus doses to the patient after eliminate the occlusion.
- 15) **Fast start:** When the Graseby V20 CC infusion pump starts, it automatically gives a faster start rate at first, and then gradually dropping to the set rate - overcoming the delay of infusion pump delivery.
- 16) **Configurable alarm limits:** from 25mmHg to 1000mmHg($kPa \times 7.5=mmHg$, $mmHg \times 0.133=kPa$).

5 Specifications

5.1 Basic Specifications

Dimensions	216 mm×131 mm×72 mm (W×D×H)
Weight	1.26 kg
Power supply	Network power supply: ~ 100 V-240 V, 50/60 Hz Internal battery:  7.4 V rechargeable Lithium battery
Rate of work	45 VA
Consumable requirements	Refer to Section 11 Precautions for Using Disposable Consumables
Maximum Infusion Rate	2000.00 mL/h

5.2 Main Performance

Infusion Rate range	0.01~2000.00 mL/h, with resolution of 0.01 mL/h
VTBI range	0.01~9999.99 mL, with resolution of 0.01 mL/h
Infusion accuracy	±3.0%(MDK consumable) ±4.0%
Precision of bolus	±8.0%
Purge Rate / Bolus Rate	1 mL/h ~ 2000 mL/h, with resolution of 1 mL/h
Purge VTBI / Bolus VTBI	0.10mL ~ 100.00mL with resolution of 0.01 mL
KVO rate	<p>This infusion pump provides two KVO modes to ensure venous patency while guaranteeing infusion safety:</p> <p>1.Constant KVO Mode (V_{KVO} rate setting range: 0.10-5.00 mL/h, minimum step value 0.01 mL/h) -When the infusion rate is $>V_{KVO}$: After the infusion task is completed, the pump automatically runs at the V_{KVO} rate to maintain venous patency. -When the infusion rate is $\leq V_{KVO}$: After the infusion task is completed, the pump continues to run at the infusion rate to maintain venous patency.</p> <p>2.Variable Speed KVO Mode (V_{KVO} rate setting range: 0.10-5.00 mL/h, minimum step value 0.01 mL/h) Users need to set the V_{KVO} rate separately for three scenarios:</p>

	<p>(a) $V_{KVO}(>10)$ rate for infusion rates > 10 mL/h, (b) $V_{KVO}(1-10)$ rate for infusion rates between 1-10 mL/h, and (c) $V_{KVO}(\leq 1)$ rate for infusion rates ≤ 1 mL/h. The system will automatically matches the KVO rate based on the infusion rate:</p> <p>-When the infusion rate is > 10 mL/h: After the infusion task is completed, the pump automatically runs at the $V_{KVO}(>10)$ rate to maintain venous patency. -When the infusion rate is between 1-10 mL/h: After the infusion task is completed, the pump automatically runs at the $V_{KVO}(1-10)$ rate to maintain venous patency. -When the infusion rate is ≤ 1 mL/h and the infusion rate is $> V_{KVO}(\leq 1)$ rate: After the infusion task is completed, the pump continues to run at the $V_{KVO}(\leq 1)$ rate to maintain venous patency. -When the infusion rate is ≤ 1 mL/h and the infusion rate is $\leq V_{KVO}(\leq 1)$ rate: After the infusion task is completed, the pump continues to run at the infusion rate to maintain venous patency.</p>
<p>Infusion Time range</p>	<p>00:00:00~99:59:59, with resolution of 1s</p>
<p>Occlusion threshold</p>	<p>25-1000 mmHg in steps of 1mmHg. Error $\pm 5\%$. (kPa $\times 7.5 = \text{mmHg}$, mmHg $\times 0.133 = \text{kPa}$)</p>

<p>Maximum infusion pressure generated by the device</p>	<p>1050mmHg</p>
<p>Occlusion alarm trigger time and Bolus dosage</p>	<p>When operated at minimum Infusion rate(1.00mL/h): < 1h when the occlusion alarm pressure threshold is set to the lowest pressure; or < 3h when the occlusion alarm pressure threshold is set to the highest pressure.</p> <p>When operated at intermediate infusion rate(25.00mL/h): < 1min30s when occlusion alarm pressure threshold is set to the lowest pressure, and the Bolus produced during occlusion is < 0.10 mL; < 2min30s, when the occlusion alarm pressure threshold is set to the highest pressure, the Bolus during occlusion is not more than 0.40 mL.</p> <p>(Tested with the MDK IV infusion set when an occlusion was created 1 meter away from the pump outlet)</p>
<p>Consumable brand</p>	<p>IV infusion set: MDK enteral feeding set: MDK blood transfusion set: Terumo</p>
<p>Supported Infusion modes</p>	<p>14 modes, RVT mode, Drug Library mode, Dose mode, Drop speed mode, RTM mode, Sequence mode, Loading Dose mode, Intermittent mode, Relay mode, Micro mode, TIVA mode, Piggy back mode, Feeding mode, Transfusion Mode.</p>

Battery running time	Intermediate rate (25.00mL/h): When fully charged, the battery can run continuously for 6h30min. Maximum rate (2000mL/h): When fully charged, the battery can run continuously for 6h10min.
Alarm Mute Time	2 min ±10s
Call Back Time	1 min ~ 60 min ± 10s
Classification	Type II CF continuous operating volumetric Infusion pump with internal power supply; Grade IP44, non AP/APG type device.
Ambient temperature and humidity	Ambient temperature of transportation and storage: -20 °C ~ + 55 °C Ambient temperature for operation: +5 °C ~ + 40 °C Ambient humidity for transportation, storage and operation: 20% ~ 90% Ambient pressure for transportation, storage and operation: 700 hPa ~ 1060 hPa
Software version	V20 CC_V1
Service lifetime	8 years

5.3 Main Functions and Common Functions

- 1) Set infusion rate, infusion VTBI and real-time data display function;
- 2) Display of completed infusion volume;
- 3) Purge / Bolus;
- 4) Alarms;
- 5) The Infusion rate will be automatically changed to KVO Rate

after the VTBI complete alarm is activated

- 6) Temporary mute for alarm sound and timer for alarm sound recovery;
- 7) Automatic free-flow stopping function;
- 8) Displays the accumulated quantity infusion and supports clearance
- 9) A variety of brands for IV infusion set are supported;
- 10) Built-in battery;
- 11) External power adapter;
- 12) Closed-loop infusion protection safety function
- 13) Contains Dose-Error Reduction Software
- 14) Electric infusion pump door
- 15) CC pressure disc

6 Structure and Operation Interface

6.1 Structural Composition

The structure of the device consists of a pump casing, a motor drive system, an input system, a storage system, a control system, a display system, a sensing and monitoring system, an alarm system and a power supply system.

Names for parts and components:

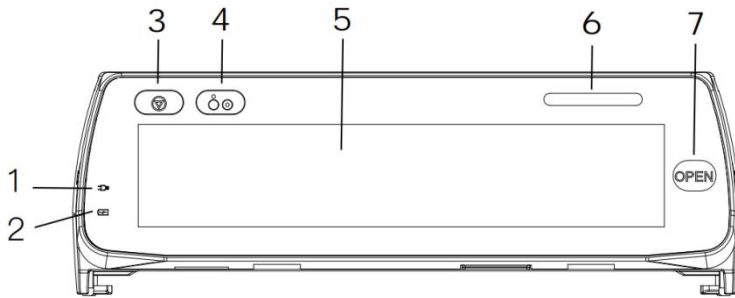

Figure 6-1-1 Front view

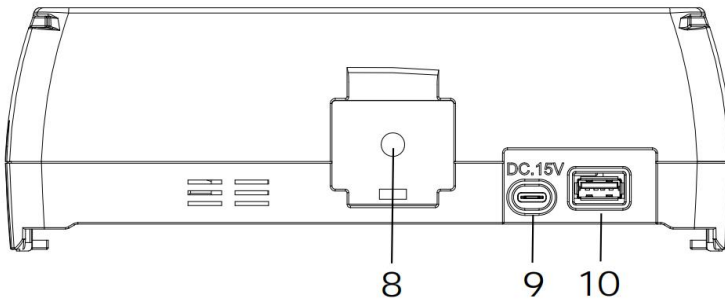
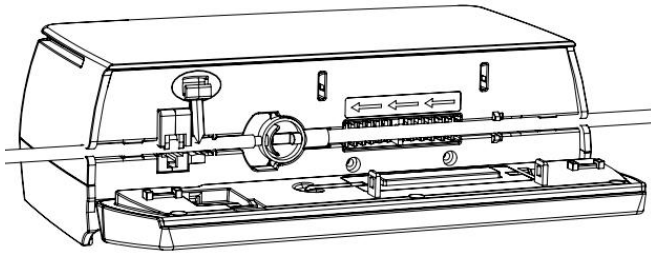

Figure 6-1-2 Back view

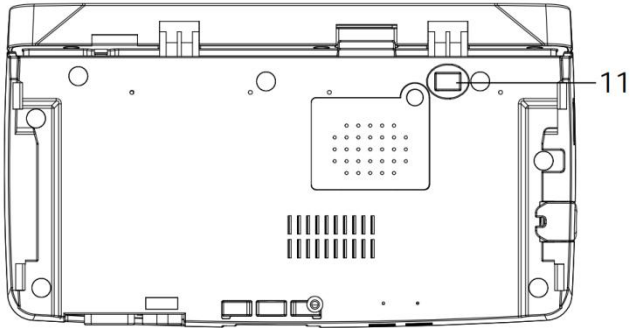

Figure 6-1-3 Upward view

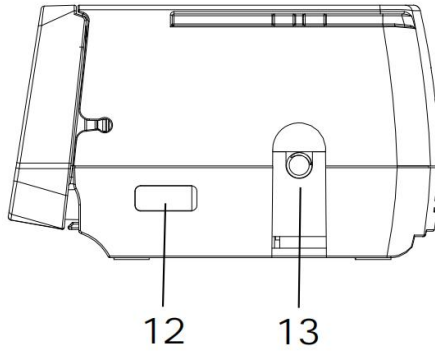

Figure 6-1-4 Side view

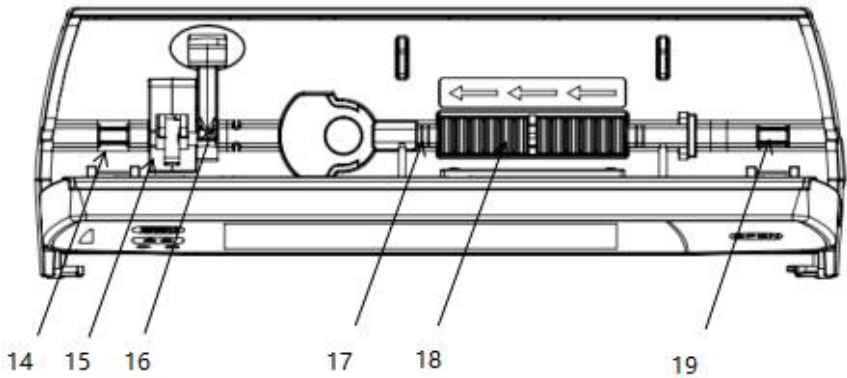

Figure 6-1-5 Pump door open diagram

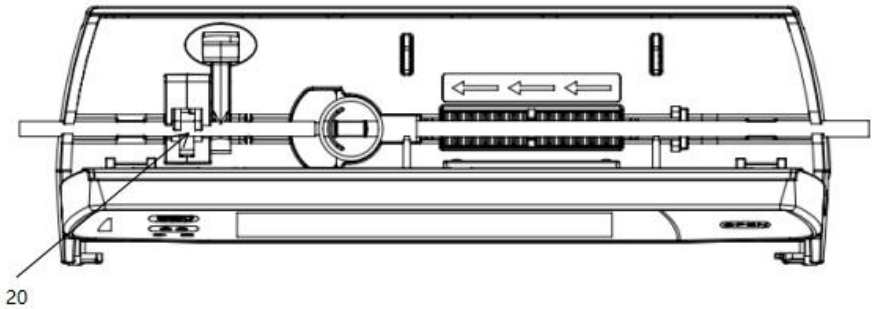

Figure 6-1-6 MDK infusion set installation diagram

1	External power indicator	2	Charging indicator	3	Start-Stop key
4	Power on/off key	5	Touch screen display	6	Operation status indicator
7	Electric pump door switch	8	Fixed pole	9	Power Port
10	Data Communication port	11	Manual pump door switch	12	Drop sensor port
13	Stack slot	14	Air in line sensor	15	Down stream occlusion sensor
16	Liquid stop clamp	17	Positioning groove for IV infusion set	18	Pump disc
19	Upper stream occlusion sensor	20	Clamp for MDK IV infusion set (Optional)		

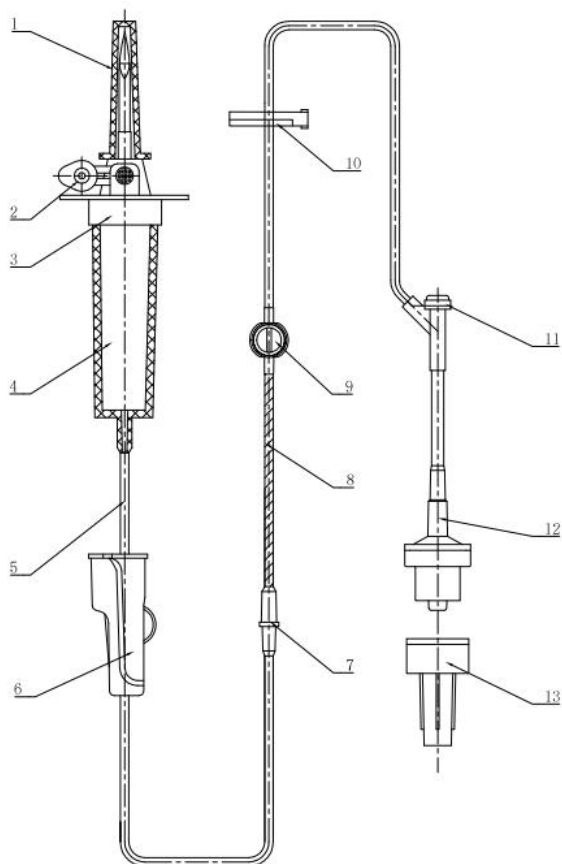

Figure 6-1-7 Structure of CC special IV infusion set

1	Cork Screw Protector Cover	8	Silicone Tubing for Pumps
2	Air Filter	9	CC Pressure Disc
3	B Corkscrew	10	One-way Check Valve
4	Pipeline	11	Needle injector
5	Dropper (general)	12	Drug Liquid Filter
6	Flow Regulator	13	External Conical Connector Protector

7	Two-Port Valve		
---	----------------	--	--

6.2 Display and Operation Interface

The display interface is shown below. Click the "Switch" button to switch the interface display.

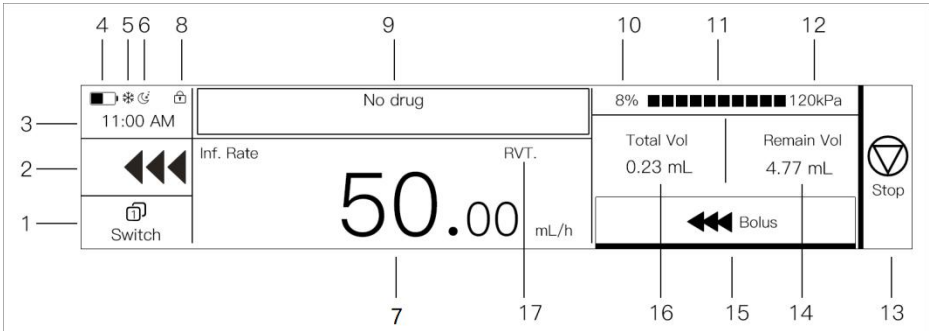

Figure 6-2-1 Operation interface on the screen 1

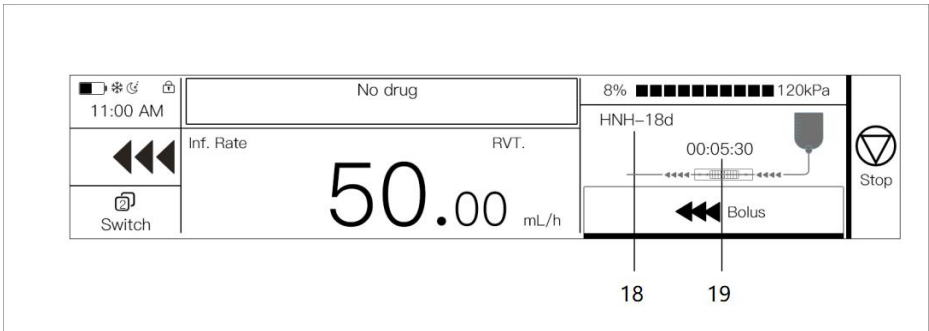

Figure 6-2-2 Operation interface on the screen 2

1	Switch	2	Infusion status	3	Time
4	Battery	5	Low temperature	6	Night mode
7	Infusion rate	8	Lock screen	9	Drug name
10	Current pressure ratio	11	Pressure accounts for	12	Upper occlusion

			progress		pressure limit
13	Start/Stop button	14	Remaining volume	15	Bolus button
16	Total volume infused	17	Infusion mode	18	Brand
19	Time remaining				

7 Operation Instructions

Install Infusion pump → Power on → Device safety self-test → Install IV infusion set → Select IV infusion set brand → Parameters setting → Prime / Purge → Start infusion → Infusion completed → Remove accessories → Power off.

Before infusion starts, please confirm that the IV infusion set in use matches the current IV infusion set setting selected in the menu. Any IV infusion set which brand is not included in the list of recommended brands must be calibrated before being used.

7.1 Installation of Infusion Pump

First loosen the locking screw, install the clamp to the pole of the infusion stand, adjust the height of the clamp, and then tighten the locking screw. The operator must make sure that the Infusion pump is positioned in a secure, stable and reliable manner.

7.2 Power on and Device Safety Self-test

7.2.1 Power on and off

Before connecting to the mains power, check if there is any foreign matter inside the power outlets (such as drug solution residue).

Connect to the mains power, check the power indicator on the pump front panel. If the indicator is not lit up, check the connection of power cable and the pump, or check if there is a power outage. Then press the power Key on the front panel to turn the device on.

After infusion therapy is completed, press the power key and click Power-Off button to turn the device off. Do not power off when the device is in operation mode, otherwise the infusion therapy will be stopped.

7.2.2 Device Safety Self-test

The pump will perform an automatic safety self-test after powered on, if the test is passed then there will be two short beeps and the operation status indicator will be lit up in stable green color. If a continuous alarming sound is initiated or there is no any sound at all, then the device cannot be used, please contact the customer service immediately.

7.3 Quick Use Guide

7.3.1 Install / Replace IV infusion set

First, press the electric pump door switch to open the pump door, press the clamp upward to make the clamp open. Straighten the infusion line below the drip chamber and place it into the positioning groove. Then close the pump door, adjust the roller clamp on the IV infusion set to its open position. The installation of IV infusion set is completed.

As above, when installing the MDK IV infusion set, it is necessary to insert the stop liquid piece for MDK IV infusion set into

the clamp for MDK IV infusion set, straighten the IV infusion set so that the IV infusion set is in the positioning groove, and then close the pump door.

Before changing IV infusion set or changing drug solution, the roller clamp on the IV infusion set has to be turned to the closed position to prevent free flow of the medication solution.

As disposables, IV infusion set must be replaced after being used for once.

To change or re-install the IV infusion set, first open the pump door, push the clamp inside pump door upward to open it and to release the infusion line. Install the IV infusion set back into the pump again, and adjust the roller clamp on the set to the open position after the IV infusion set installation is done.

If the electric pump door cannot be opened by pressing the electric pump door switch in standby mode, press the "manual pump door switch" at the bottom of the device to open the pump door in an emergency, replace the IV infusion set and re-check whether the pump door is normal before use.

7.3.2 Select IV infusion set

After the infusion pump is powered on and the safety self-test is passed, the parameter setting page will show up. Click the Brand button in the upper right corner to enter the IV infusion set brand selection page.

After clicking an IV infusion set brand to make a selection, the system will automatically return to the parameter setting page. Please check if the IV infusion set displayed on the right side of the

screen matches the set that is being used.

It is possible that the IV infusion set from the same brand may have different characteristics if they are from different lots, which will affect their infusion accuracy if they are not calibrated before use. In that case, calibration of the IV infusion set is recommended, which is described in Section 10 Accuracy Calibration for IV infusion set.

HNH-18d			
Return			

Figure 7-3-2 Select IV infusion set

7.3.3 Install Drop Sensor (optional)

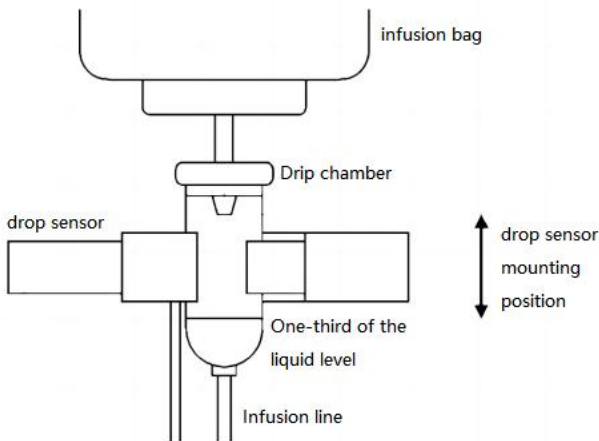

Figure 7-3-3 Drop sensor installation

Connect the drop sensor to the drip transfer interface of the device, and install the drop sensor on the drip pot. If you need to

replace the infusion set, remove the drop sensor, pull out the interface, and reinstall it.

To ensure reliable and accurate drop count detection, the drop sensor should be installed as close to the liquid level as possible, and the liquid level height should be 1/3 of the drop pot. During the infusion process, it is necessary to avoid tilting the drop sensor, direct sunlight, and strong light.

For the cleaning of the drop sensor, please refer to the instruction manual "15 Service and Maintenance" to wipe the outer surface of the drop sensor.

7.3.4 Install CC pressure disc

Prime the extension set, massaging pressure disc to prevent ballooning and ensuring all air removal, then open the pump door and insert the CC pressure disc into CC the pressure transducer. As shown in the following picture.

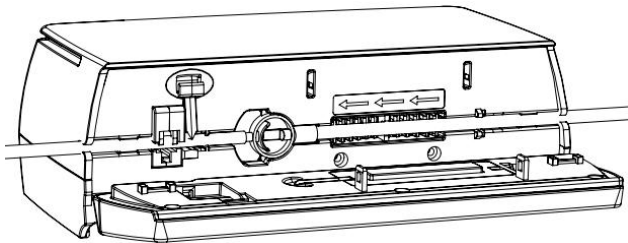

Note: CC Pressure Transducer- Detects if an Infusion set with a pressure disc is fitted. The pressure transducer will measure positive pressures within the infusion set.

Note: When you are using a CC pressure disc, you should prime the infusion set before installing the disc to the CC pressure

transducer. If you need to prime the infusion set after installing the CC pressure disc, the disc must be removed before priming and reinserted after priming.

Note: Purge the infusion set, massaging the CC pressure disc to prevent ballooning and ensuring all air removal.

Warning: To remove or insert a CC pressure disc from or into CC pressure transducer assembly, insert finger into the recess in the CC pressure disc and push rightward carefully. Do not pull the infusion set to remove or to insert the CC pressure disc.

Warning:

CC pressure transducer:

Fully Dedicated - to start an infusion, a pressure disc must be fitted;

Semi Dedicated - CC specific consumables or ordinary infusion set can be used simultaneously. Please consult with your local product dealer if the device supports semi dedicated use.

7.3.5 Set Infusion Parameters

Click on "Infusion Rate" on the screen to enter the infusion rate change page. Enter the flow rate value to be set, and click the "✓" button to complete the input.

The method for setting the preset amount and total time is the same as the method for setting the infusion rate mentioned above. After setting, click the "✓" button to confirm the parameters.

Infusion Rate Change mL/h						HNNH-18d					
✎	-	-	-	-	.	-	-				
0	1	2					✓	↶			

Infusion VTBI Change mL						HNNH-18d					
✎	-	-	-	-	.	-	-				
0	1	2	3	4	5	6	7	8	9	✓	↶

Infusion Time Change H:M:S						HNNH-18d						
✎			-	-	:	-	-	:	-	-		
0	1	2	3	4	5	6	7	8	9	✓	↶	

Figure 7-3-5 Set infusion parameters

7.3.6 Purge

After the infusion parameters are set, click the "Start Infusion" button and the device will pop up an exhaust confirmation page. Confirm that the pipeline is disconnected from the patient. Click the "Confirm" button on the screen, and the device will run at the purge rate and total amount set by the system to quickly empty the gas in the infusion pipeline (click the "Stop Purge" button to stop purge).

Sure to purge	
Cancel	OK

Figure 7-3-6 Confirm to purge

After the purge, enter the infusion pause interface. If there are still air bubbles in the infusion line, click the "purge" button to purge again, and repeat the above operation until there are no air bubbles.

The purge volume is not included in the Infusion accumulation. When the Purge is running, the Air-in-line alarm is not suppressed, and the other alarms are normal.

Note: When using a CC pressure disc, you should prime the infusion line before installing the disc to the CC pressure transducer. If you need to prime the infusion line after installing the CC pressure disc, the disc must be removed before priming and reinserted after priming.

Note: To purge the infusion line, massaging the CC pressure disc to prevent ballooning and ensuring all air removal.

7.3.7 Start Infusion

Press the Start/Stop key or click the start button and the pump will start to run according to the set infusion parameters, as shown in the following figure.

When the device is working, after revising the infusion flow rate in real time, the motor will synchronously change the voltage to increase the motor rate, so that the pump can synchronously reach the changed flow rate.

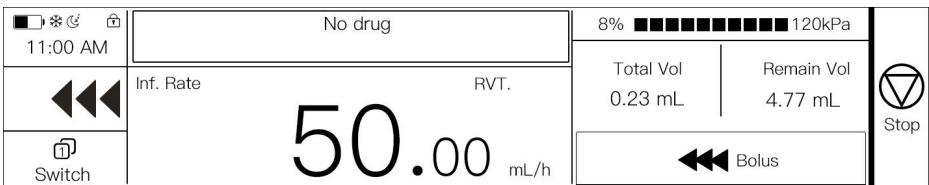

Figure 7-3-7 Infusion interface

7.3.8 Infusion Completed

The infusion is completed when the infusion accumulation volume reaches the VTBI set for the infusion task.

If KVO is enabled, the device will convert to the KVO Rate to continue running automatically and trigger the "KVO" high priority alarm at the same time. Click the "Stop" button or press the "Stop" button to enter the infusion pause interface. Click "Exit Infusion" to enter the infusion mode selection interface. At this time, you can reset the infusion parameters and start a new infusion task.

After the infusion task is completed, remove the infusion attachment, follow the method of replacing the infusion set, remove the infusion set that is no longer in use, press the "Power" button, and click "Shutdown" to turn off the device. Pull the circular ring on the fixed clamp base upwards and remove the infusion pump by pulling it outward.

7.4 Pause or Stop Infusion

Press the Start/Stop key or click the stop button during infusion operation can pause the operation, as shown in the following figure.

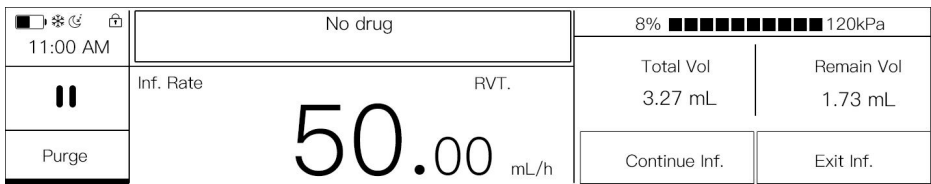

Figure 7-4 Infusion pause

On the Infusion pause page, press the Start/Stop key or click the start button again can start the device operation, and the device will continue to infuse the remaining volume based on the set Infusion rate. If you click the "Exit Infusion" button, the device will enter the infusion mode selection interface, where you can reset the infusion parameters and start a new infusion task.

7.5 Bolus

In the infusion state, click the "Bolus" button to enter the bolus selection page. If "Last Bolus" is selected, the device will take the bolus according to the parameters of the previous bolus; If "Automatic Bolus" is selected, the device will enter the bolus parameter setting page. After setting and confirming the bolus parameters, click the "Start Bolus" button, and the infusion pump will enter the pill infusion state. After the bolus dosage reaches the set value, stop the infusion of the bolus, and the infusion pump returns to the normal infusion operation state before entering the bolus infusion to continue infusion. The bolus dosage is included in the accumulated infusion volume.

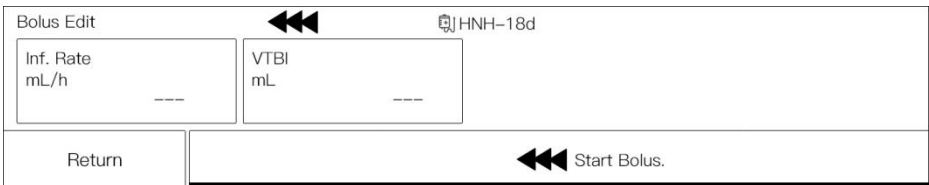

Figure 7-5-1 Bolus setting interface

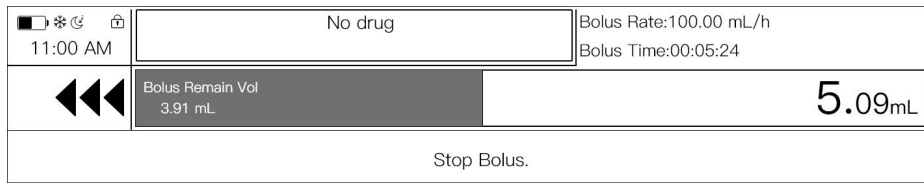

Figure 7-5-2 Bolus running interface

7.6 Lock and Unlock Screen Function

The device automatically locks the screen after running for a period of time. When the device is in the lock screen, click the screen and a prompt will pop up asking whether to unlock the screen, click the "Confirm" button to unlock the screen.

Auto Lock time settings See Home - Setting - Auto Screen Lock.

7.7 Infusion Mode Selection and Setting

Except for the RVT mode on the home screen, there are other infusion modes on the Infusion Mode page: Dose mode, Drug Library mode, Drop speed mode, RTM mode, Sequence mode, Loading Dose mode, Intermittent mode, Micro mode, Relay mode, TIVA mode, Piggyback mode, Feeding mode, Transfusion mode.

In the RVT setting page, the infusion rate, VTBI and infusion time can be set in a variety of combinations, forming the following four combinations of infusion mode: rate + volume (R+V) Mode, rate + time (R+T) Mode, volume + time (V+T) Mode, rate (R) Mode. Therefore, there are 17 different infusion modes for the device in total.

Please follow the instructions in the "Quick Use Guide" above

for setting the RVT mode. The following is a brief introduction to the settings of other modes.

7.7.1 Dose Mode

Enter the Dose mode settings interface, as shown in Figure 7-7-1.

Set the dosage, solution volume, concentration, body weight, dose rate, infusion rate, preset amount, and total time separately. After setting the parameters, click the "Confirm" button to confirm the infusion parameters.

Dose				HNNH-18d	
Dose mg ---	Solution mL ---	Conc. mg/mL ---	Weight kg ---		
Return	Previous Page	1/2	Next Page	OK	

Dose				HNNH-18d	
Dose Rate mg/kg/h ---	Inf. Rate mL/h ---	VTBI mL ---	Inf. Time H:M:S --:--:--		
Return	Previous Page	2/2	Next Page	OK	

Figure 7-7-1 Dose mode setting

In the Dose Mode Settings interface, click "Unit" to the right of any parameter in "Dose", "Concentration" and "Dose Rate" to select different unit expression modes, and the other two corresponding units will be automatically adjusted.

Concentration and Infusion Rate are calculated as follows:
Concentration calculation formula:

$$\text{Concentration(mg/mL)} = \frac{\text{Dose (mg)}}{\text{Solution (mL)}}$$

Infusion rate calculation formula:

$$\text{Infusion Rate(mL/h)} = \frac{\text{Dose Rate (mg/kg/h)} \times \text{weight (kg)} \times \text{Solution (ml)}}{\text{Dose (mg)}}$$

$$\text{Infusion Rate(mL/h)} = \frac{\text{Dose Rate (mg/h)} \times \text{Solution (ml)}}{\text{Dose (mg)}}$$

7.7.2 Drug Library Mode

Enter the drug library mode settings interface, Figure 7-7-2.

Select the name and the specific specifications of the drug that requires infusion. The device will enter the drug library mode settings page and automatically brings in the drug-related parameters. At this point, the drug name and drug specifications are displayed in the title bar of the parameter settings page. After setting the parameters, click "Confirm" to confirm the parameters.

Drug Library		HNNH-18d		ADREnaline		5.00mg / 50.00mL	
Dose mg	5.00	Solution mL	50.00	Conc. mg/mL	0.10	Weight kg	---
Return	Previous Page	1/2	Next Page	OK			

Drug Library		HNNH-18d		ADREnaline		5.00mg / 50.00mL	
Dose Rate mg/kg/h	0.10	Inf. Rate mL/h	---	VTBI mL	---	Inf. Time H:M:S	---:---:---
Return	Previous Page	2/2	Next Page	OK			

Figure 7-7-2 Drug Library mode setting

The Drug library mode has built-in DERS (Dose-error Reduction Software) functionality to reduce medication errors and improve infusion safety.

7.7.3 Drop Speed Mode

Enter the system maintenance interface and open the drip transfer function.

This infusion pump can be used in conjunction with the matching drop sensor to monitor the flow rate in the infusion pipeline. When the deviation between the drop speed and the set infusion rate exceeds 50%, an alarm prompt will be triggered.

Select to enter the drop speed mode setting interface, as shown in the following figure. After setting the infusion rate parameter, it is automatically converted to a speed parameter display, and other operations are the same as the RVT mode introduced in the Quick Use Guide section.

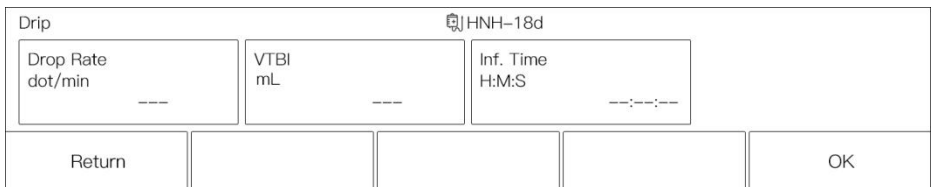

Figure 7-7-3 Drop Speed mode setting

7.7.4 RTM Mode

Enter the RTM mode(Ramp and Taper Mode) settings interface, as shown in Figure 7-7-4

RTM.		HNH-18d		
Total Time H:M:S --:--:--	Up Time H:M:S --:--:--	Down Time H:M:S --:--:--	VTBI mL ---	
Return	Previous Page	1/2	Next Page	OK

RTM.		HNH-18d		
Plateau Rate mL/h ---				
Return	Previous Page	2/2	Next Page	OK

Figure 7-7-4 RTM mode setting

In the RTM mode parameters, VTBI, Up Time, and Down Time must be set. After setting one of the two parameters of Plateau rate or Total Time, the other parameter will be calculated automatically. After setting the parameters, click "Confirm" to confirm the parameters.

When the device is started, the infusion rate gradually increases from 0 to Plateau Rate during the Up Time and then maintains the rate. When the remaining time is equal to the Down Time, the infusion rate gradually decreases until it reaches 0 and the infusion is completed.

7.7.5 Sequence Mode

Select to enter the sequence mode setting interface and set the number of sequences (up to 10 groups), Click the "Next" button at the bottom right to enter the infusion parameter settings, as shown in the following figure.

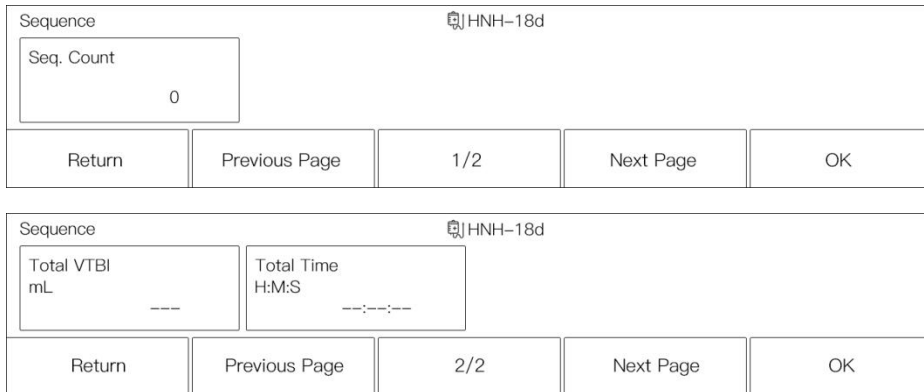

Figure 7-7-5 Sequence mode setting

As shown in Figure, if any two of the three parameters are set, including preset amount, total time, and infusion rate, the device will automatically calculate another parameter.

Click the "Next" button, set 1 to 10 different infusion parameters according to clinical needs, view the total preset volume and time, and click the "Confirm" button to confirm the infusion parameters.

After the device completes the first set of infusion parameters, it automatically switches the flow rate to complete the second set of parameters until all set parameters are completed and the infusion is completed.

7.7.6 Loading Dose Mode

Enter the Loading Dose mode settings interface, as follows.

Loading Dose		HNNH-18d		
VTBI mL ---	Loading VTBI mL ---	Loading Rate mL/h ---	Maintain Rate mL/h ---	
Return	Previous Page	1/2	Next Page	OK

Loading Dose		HNNH-18d		
Loading Time H:M:S --:--:--	Maintain Time H:M:S --:--:--			
Return	Previous Page	2/2	Next Page	OK

Figure 7-7-6 Loading dose mode setting

As shown in the figure, set the preset amount, loading amount, loading rate, and maintain rate. The device automatically calculates the loading time and maintain time, and click the "Confirm" button to confirm the infusion parameters. After the device is started, infusion starts according to the loading rate. When the cumulative infusion amount equals the preset loading amount, the infusion automatically continues according to the maintain rate. When the cumulative infusion amount reaches the preset amount, the infusion is completed.

7.7.7 Intermittent Mode

Enter intermittent mode settings interface.

As shown in the figure, set the Single VTBI, Single Rate, Intermittent Time and Maintain Rate, and click the "Confirm" button to confirm the infusion parameters. After the device is started, the infusion will start at the Single Rate. When the infused volume is equal to the single VTBI, the device will automatically continue infusion according to the Maintain Rate. When the Maintain Rate is

set to 0, the device will run at 0 mL/h. The device runs at Maintain Rate until the time is equal to the Intermittent Time, the device automatically switches to the Single Rate to continue the infusion, so as to cycle.

Intermittent		HNNH-18d		
Single VTBI mL ---	Single Rate mL/h ---	Inter Time H:M:S --:--:--	Maintain Rate mL/h ---	
Return	Previous Page	1/2	Next Page	OK

Intermittent		HNNH-18d		
Intermittent count 0				
Return	Previous Page	2/2	Next Page	OK

Figure 7-7-7 Intermittent mode setting

7.7.8 Micro Mode

Enter Micro mode settings interface.

Set any two of the Infusion Rate, VTBI, and Infusion Time, the device will automatically calculate another parameter. The Infusion Rate should not exceed 100mL/h. After the device is started, the infusion starts at the Infusion Rate. When the infused volume is equal to the VTBI, the infusion will be stopped automatically.

When only sets the Infusion Rate, the device runs at the Infusion Rate until the operator stops the infusion or the device triggers a high priority alarm to stop the infusion.

Micro		HNH-18d		
Inf. Rate mL/h ---	VTBI mL ---	Inf. Time H:M:S --:--:--		
Return				OK

Figure 7-7-8 Micro mode setting

7.7.9 Relay Mode

The infusion pumps can be installed on our infusion workstation for advanced application functions such as relay infusion and drug library management through the Infusion Information Collection System.

7.7.10 TIVA mode

TIVA (total intravenous anesthesia) is a mode of intravenous anesthesia administration. It controls the infusion rate of intravenous anesthesia drugs via a computer to maintain the concentration of the drug in the plasma or effect chamber within a preset target range. This mode can precisely control the depth of anesthesia, reduce drug waste, and improve the safety of surgery.

TIVA mode is widely used in various surgeries requiring precise control of the depth of anesthesia, such as neurosurgery, heart surgery, etc. Due to its ability to provide a stable anesthetic effect and reduce drug fluctuations, the TIVA model has significant advantages in improving surgical success rates.

Enter the TIVA mode setting interface.

Set body weight, loading dose, and any two parameters in dose, solution volume, and concentration to automatically calculate

another parameter value; Setting any parameter in the loading time and loading rate can automatically calculate another parameter value; Setting any parameter in maintain rate or flow rate can automatically calculate another parameter value.

TIVA		HNNH-18d		
Dose mg ---	Solution mL ---	Conc. mg/mL ---	Weight kg ---	
Return	Previous Page	1/3	Next Page	OK

TIVA		HNNH-18d		
Loading Dose mg/kg ---	Loading Time H:M:S --:--:--	Loading Rate mL/h ---	Maint. Dose Rate mg/kg/h ---	
Return	Previous Page	2/3	Next Page	OK

TIVA		HNNH-18d		
Maintain Rate mL/h ---				
Return	Previous Page	3/3	Next Page	OK

Figure 7-7-10 TIVA mode setting

7.7.11 Piggyback Mode

1) Install the infusion set and purge it according to the instructions for the use of piggyback consumables.

2) On the infusion mode page, select the piggyback mode, click the Primary button to select the infusion mode, set the infusion parameters as described in the above chapter, and click OK. The Secondary button appears in the bottom right corner of the page.

3) Click on the Secondary button to set the same settings as

the Primary. After setting up, click "Start Infusion" to start normally.

4) After starting the operation, due to the high liquid level in the secondary bag, it will flow down first; Until the liquid in the secondary bag is completely infused, it will automatically switches to the primary bag flowing downwards.

5) In step 3), if you do not select the Secondary button, you can directly click Start to start the infusion, and the device runs according to the infusion parameters of the Primary; During infusion operation, you can click the pause button, click the secondary button on the pause page, and follow step 3 to start the second bag of liquid infusion.

6) After the device completes the second bag of liquid infusion, it automatically switches to the first bag of liquid infusion until the primary preset amount is completed or when the infusion is empty, an alarm stops infusion.

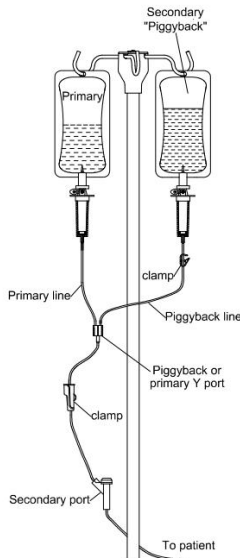

7.7.12 Feeding Mode

Enteral nutrition infusion refers to the technique of precisely controlling the administration of enteral nutrition fluids (such as intact protein formulas, short peptide formulas, etc.) into a patient's gastrointestinal tract via a nasogastric tube, nasoenteric tube, or stoma tube using an infusion pump. This method is suitable for patients with dysphagia, normal gastrointestinal function but unable to eat independently, to maintain their nutritional and metabolic needs. Enteral nutrition fluids must be infused at a constant rate to avoid gastrointestinal intolerance (such as diarrhea, bloating) or the risk of aspiration. The infusion pump can accurately regulate the rate, especially for critically ill patients, postoperative patients, or those requiring long-term nutritional support, ensuring the efficiency and safety of nutrient absorption.

Mode Features:

Precise Rate Control: Supports fine adjustments down to 0.1 mL/h to meet varying flow rate requirements from the initial adaptation period to the stable phase.

Safety Alerts: Equipped with alarms for tube blockage, completion of infusion, and abnormal pressure to reduce the risk of tube dislodgement.

Wide Compatibility: Compatible with various viscosities of nutrition fluids and standard enteral feeding tubes, reducing issues of sedimentation or blockage.

Precautions:

- Confirm the tube position (e.g., in the stomach or intestine) before infusion to avoid complications from misplacement.

- Shake the nutrition fluid well and control its temperature (recommended to be close to body temperature). Rinse the tube with warm water before and after infusion to prevent blockage.

- Start the initial infusion at a low rate (e.g., 20-50 mL/h) and gradually increase it, monitoring the patient's tolerance.

- For long-term use, regularly replace the tube and strictly follow aseptic procedures to avoid contamination.

Install the special nutrition tube according to the operation instructions in Section 7.3.1, and select the consumables as the special nutrition tube according to the operation instructions in Section 7.3.2. Click Home-Infusion Mode-Feeding Mode to enter the page for mode parameter settings. The total infusion volume (mL), flow rate (mL/h), single infusion duration, and pressure alarm threshold need to be set. It is recommended to adjust the flow rate in stages until the target rate is reached.

According to the method in Section 7.3.3, set two out of the three items: feeding flow rate, feeding quantity, and feeding time, and the device will automatically calculate the third item. When the feeding flow rate is set and both the feeding quantity and feeding time are set to 0, the set speed will be maintained until the fluid bag is empty. After setting the feeding parameters and removing air bubbles from the infusion line according to Section 7.3.4, press the Start-Stop button or click the Start button to begin the infusion.

7.7.13 Transfusion Mode

The transfusion mode refers to the process of precisely controlling the infusion rate and volume of blood or blood components (such as red blood cells, plasma, platelets, etc.) using an infusion pump to ensure the safe and efficient administration of blood products to patients.

Blood transfusion requires strict control of the flow rate and total volume. Infusing too quickly may lead to risks such as circulatory overload and hemolytic reactions, while infusing too slowly may affect the timeliness of treatment. The infusion pump achieves constant-rate infusion through preset parameters, especially for critically ill patients, children, and scenarios requiring precise dose control.

Mode Features:

Precise Rate Control: Supports fine adjustments down to 0.1 mL/h to meet the needs of different patients.

Intelligent Protection: Equipped with air bubble detection, tube blockage alarms, and pressure limit alarms to prevent transfusion accidents.

Convenient Operation: Features a built-in blood transfusion-specific mode to simplify parameter settings and improve emergency efficiency.

Precautions:

- Strictly verify blood type, expiration date, and patient information before transfusion.

- Use the recommended blood transfusion-specific tubing to

avoid hemolysis caused by material issues with regular infusion tubing.

- Blood products should be warmed to room temperature in advance, and vigorous shaking is prohibited.

- Monitor the patient's vital signs throughout the process and be vigilant for allergic reactions or transfusion-related complications.

Install the special blood transfusion tube according to the operation instructions in Section 7.3.1, and select the consumables as the special blood transfusion tube according to the operation instructions in Section 7.3.2. Click Home-Infusion Mode-Transfusion Mode to enter the mode parameter setting page. During operation, the following must be clarified: total infusion volume (mL), flow rate (mL/h), and pressure alarm threshold (adjusted according to vascular conditions). It is recommended to start with a low flow rate and gradually adjust to the target rate after observing no adverse reactions.

The method for setting transfusion mode parameters is the same as that for the RVT mode. The three parameters of flow rate, infusion volume, and infusion time can be set to form the following four combination modes: flow rate + total volume mode, flow rate + time mode, total volume + time mode, and RVT mode (without total volume and time).

After setting the transfusion parameters and removing air bubbles from the infusion line, press the Start-Stop button or click the Start button to begin the infusion.

7.8 Rate Locking Function

In the Home Menu - setup page, you can click to turn on/off the rate lock function. If Rate Lock is enabled, when the infusion rate has been set and the infusion started, the rate lock prompt will appear on the display following any rate titrations or bolus infusions.

Note: When rate lock is enabled, the following are unavailable:

Changing the infusion rate;

Titration;

Bolus/purge;

Switching the pump off;

V+T infusion mode.

Note: A bolus cannot be administered if the rate lock is active. During bolus the pressure limit alarm is temporarily increased to the maximum level.

7.9 CC Setup

7.9.1 CC Auto Set Pressure

In the Home Menu - CC setup page, you can click to turn on/off the Auto-set pressure function.

If the Auto Set Pressure Option is enabled then the pump automatically adjusts the pressure occlusion limit.

After 15 minutes of infusion the pump automatically adjusts the occlusion pressure limit to above the average infusion pressure A, When the real-time pressure $P_r > A + \text{**mmHg}$, the alarm will be generated. The average infusion pressure A takes from the average of the latest 5 minutes of infusion.

Note 1: **mmHg is the value set by the user in the system. The range is 15-100 mmHg.

Note 2: When real-time pressure $P_r \leq 100\text{mmHg}$, the alarm condition is real-time P value $> A + \text{**mmHg}$; When the real-time pressure $P_r > 100\text{mmHg}$, the alarm condition is real-time P value $> A \times (1+y\%)$, and the real-time P value should be less than the set pressure level at the same time. ($y\%$ is 30%).

Note 3: Average pressure value calculation method: the average infusion pressure of the last 5 minutes, the pressure curve is refreshed every 10 seconds, and a pressure value can be saved every 10 seconds /1 second for calculating the average pressure.

7.9.2 CC Pressure Alarm Threshold

In the Home Menu - setup page, click "CC setup" set the alarm pressure threshold, the threshold is (25-1000mmHg), click the numeric soft keyboard to set the desired value and click the " \checkmark " button to complete the input. Press the "Back" button on the screen again to return to the previous interface.

7.9.3 CC Pressure Level Chart

During the infusion process, click "Switch" to enter the next interface, then click "Switch" again to display the real-time CC pressure level trend chart. To return to the previous infusion interface, try click "Switch" again.

1. Click the infusion line pressure button to display the pressure trend curve and real-time pressure value and pressure alarm level for the last 20 minutes. Click the "Confirm" button to return to the previous interface;

2. Click on the pressure value section on the right to adjust the pressure alarm pressure level. Click on the numeric keypad to set the desired value and click the "√" button to confirm the input; (In steps of 1mmHg)

3. Press the Auto button to activate the Auto Set Pressure function, but it will take effect 15 minutes later after the infusion is started. After the infusion is started, the average pressure value should be calculated. If the Auto button is not clicked until 15 minutes after the infusion start, this function will immediately take effect.

4. Press the Auto button, and before the Auto function takes effect, the alarm will still be triggered according to the set pressure alarm level threshold.

5. Click on the trend chart to view the pressure trend chart for the past 12 hours. Use the + and - keys to view the

pressure trend chart at 15 minute intervals. You can check the latest 15 minutes trends chart, press the + to display the values from the previous 15-30 minutes. Press the "Confirm" button to return to the real-time pressure page.

6. If you click+/- to modify the pressure alarm threshold, it will be displayed at the bell icon, and the position and display value of the horizontal dashed line in the trend chart will be adjusted accordingly.

7.10 View Log

On the Home - Event Log Page, event logs such as device infusion status and alarm can be displayed. Click this event can view the detailed event information such as Infusion Rate, VTBI, time, Alarm priority and time.

When the pump log store reaches the upper limit of the pump capacity, the oldest log will be overwritten by the new log.

Through the infusion workstation, all infusion and alarm log information can be stored and queried in unlimited, and the log information can be printed out on the Internet to facilitate the needs of medical management.

When the alarm system is powered off, the log still exists.

Finish PCA Inf.	23-06-21 16:18	>	Stop Inf.	23-06-21 16:08	>
Pause Inf.	23-06-21 16:18	>	Pause Inf.	23-06-21 16:08	>
Start PCA Inf.	23-06-21 16:17	>	Start Inf.	23-06-21 16:08	>
Home	Previous Page	1/1667	Next Page		

Figure 7-10 Log view

8 Alarms

Alarm refers to the infusion changes caused by the abnormal infusion circuit or the failure of the Infusion pump itself, which leads to the failure of the infusion to the patient. The Infusion pump prompts the medical staff through sound, light, screen signs and other ways.

Alarm classification prompts of the device:

No.	Alarm	Priority	Alarm category	Alarm conditions
8.1	Door Open	High	Latching	The pump door is not closed during infusion or purge.
8.2	IV-Set Setup Fail	High	Latching	IV-Set are not properly installed.
8.3	OCCL (Occlusion)	High	Latching	When the infusion line is occluded.
8.4	Upstream Occlusion	High	Latching	When the upstream infusion line is occluded.
8.5	End of Infusion	High	Latching	When the infused volume is equal to the VTBI.
8.6	Air-in-line	High	Latching	Air bubbles are detected in the line.
8.7	Battery Empty	High	Latching	When the internal battery is running out.
8.8	Battery&External Power Disconnect	High	Unlatching	When the device is running, the battery and external power is

				disconnected at the same time.
8.9	Motor Err.	High	Latching	In the event of a motor failure.
8.10	Com. Err. (Communication error)	High	Latching	Monitor the CPU for communication handshake errors.
8.11	Battery Error	High	Latching	The device does not detect battery signal or battery disconnect when plug in the external power.
8.12	KVO	High	Latching	The infusion is complete with KVO is enabled.
8.13	KVO End	High	Latching	KVO status run for 30 minutes until the KVO task is complete.
8.14	Standby End	High	Latching	When standby is end.
8.15	No AC Power	Low	Unlatching	When the device is disconnected from the external power and operated with batteries.
8.16	Call Back	Low	Unlatching	The device is ready to start the infusion, but the device is not started and the device is placed without operation for the set time.

8.17	Low Battery	Low	Unlatching	When the internal battery power is low.
8.18	Near End of Infusion	Low	Unlatching	When the remaining time is less than or equal to the set near end of infusion time.
8.19	Drip Rate Error	High	Latching	When used in conjunction with a drop sensor, when the deviation between the drop rate and the set infusion flow rate exceeds 50%
8.20	CC Line Occlusion	High	Latching	The pressure measured in the extension line of the CC pressure disc is too high and exceeds the alarm limit.
8.21	CC Pressure Disc Out	High	Latching	The CC pressure disc has been removed from the CC pressure transducer during infusion.
8.22	Needle Fall off Alarm	High	Latching	During the infusion, the needle becomes detached from the patient's injection site.

The device alarm indicator characteristics:

Alarm type	Indicator color	Flicker frequency		Ratio
High priority	Red	2 Hz	0.7 Hz(Battery & External Power Disconnect alarm)	50%
Medium priority	/	/		/
Low priority	Yellow	Normally open		100%

High-priority and low-priority alarms are distinguished in sound and light according to standard requirements. When an alarm occurs, the operator can accurately detect it at 1m away from the alarm system. The delay time of triggering the alarm signal is not more than 2s.

After powering on, the status indicator lights up, and the device automatically conducts a safety check. After passing the self-check, you will hear two short beeps of "DiDi", which means that the alarm system is normal. If the status indicator does not light up or you hear a continuous alarm sound or no prompt sound after booting, it means that the alarm system is faulty and the device cannot be used normally. It can be put into use after being repaired.

The sound pressure range of the audible alarm signal is 60-95dB.

Note that this device prohibits access to the change or storage change alarm function. In the process of adjusting the alarm limit or alarm preset, the operation of the alarm system still runs according to the last setting. This device alarm is a technical alarm state.

=====



Caution

Latching alarm signal: The alarm signal that continues to be generated after the trigger event no longer exists, and does not stop until the operator deliberately acts (click the " ✓ " button);

Unlatching alarm signal: When the related trigger event is no longer When it exists, automatically stop the alarm signal generated.

device alarm announcement sequence:

High priority alarm sound priority principle, that is, when the device is in the low priority alarm sound state, when a high priority alarm is generated, the original low priority alarm sound is interrupted, the high priority alarm sound is broadcast, and the high priority alarm sound is displayed at the same time Level alarm prompt information.

The device is in a high priority alarm. When a low priority alarm is generated, the high priority alarm continues to broadcast without being interrupted.

The device is in low priority alarm. When a low priority alarm is generated, it still reports a low priority tone and displays the latest alarm prompt information.

The device detects that a visual alarm and an audible alarm appear immediately.

When the power loss time is less than 5 seconds, the alarm settings before the power loss will automatically restore.

=====

8.1 Door Open Alarm

Cause: When the infusion pump is running, if the pump door is not closed, or the pump door is opened by accident, the device will

trigger an alarm, stop running, make a high priority alarm sound, the screen appear with the message "Door Open" and the operation status indicator flash red at the same time.

Solution: Click the "Confirm" on the screen to clear the alarm, the word " Door Open " disappears, and returns to the infusion pause interface. Check the pump, close pump door and continue to operate.

8.2 IV-Set Setup Fail Alarm

Cause: When operation is started without an IV infusion set being installed on the pump, the device triggers an alarm, stops running, make a high priority alarm sound, the screen appears with the message "IV-Set Setup Fail" and the operation status indicator flashes red at the same time.

Solution: Click the "Confirm" button on the screen to clear the alarm, the word "IV-Set Setup Fail" disappears, and returns to the infusion pause interface. Open the pump door and install the IV infusion set before continuing.

8.3 Occlusion Alarm

Cause: When the infusion line is occluded, occlusion sensor detects that it is exceeding the set value, the device will trigger an alarm, stop running, make a high priority alarm sound, the screen appear with the message "OCCL" and the operation status indicator flash red at the same time.

At the same time, as a infusion safety protection mechanism, the motor reverses back to pump a small amount of liquid medicine

to reduce the dose of the bolus before occlusion relief.

This alarm is triggered when not using the CC specialized infusion tube and there is occlusion by using ordinary consumables. Once a CC specialized infusion tube is installed, an alarm will be triggered according to "CC line occlusion" when any blockage occurs.

Solution:

- 1) Click the "Confirm" button on the screen to clear the alarm and the message " OCCL " disappear.
- 2) Check whether the IV infusion set line is kinked, whether the patient presses into the infusion line and other issues, eliminate the problem and restart the infusion.
- 3) If there is still an occlusion alarm, shut off the roller clamp on the IV infusion set, open the pump door, pull out the IV infusion set, check whether the filter or the needle on IV infusion set is occluded, change to a new IV infusion set if necessary and restart infusion.

8.4 Upstream Occlusion Alarm

Cause: When the roller clamp between the bag and the pump is left closed by mistake, the infusion line will become flat when the infusion gets started. The device will trigger an alarm, stop running, make a high priority alarm sound, the screen appear with the message "Upstream Occlusion" and the operation status indicator flash red at the same time.

Solution:

- 1) Click the "Confirm" button on the screen to clear the alarm and the message "Upstream Occlusion" disappear.

- 2) Check whether the tube of the IV infusion set is kinked, whether the stop pulley is opened, whether the bag has the liquid medicine, etc., and restart the infusion after troubleshooting.

8.5 End of Infusion Alarm

Cause: If KVO is disabled, When the infused volume reaches the VTBI, the device will trigger an alarm, stop running, make a high priority alarm sound, the screen appear with the message "End Of Infusion" and the operation status indicator flash red at the same time.

As a infusion security mechanism, If KVO is enabled, the device will automatically convert to KVO Rate to continue the infusion.

Solution: Click the "√" button on the screen to clear the alarm and the message "End of Infusion" disappears. The device can be set up and used again.

8.6 Air-in-line Alarm

Cause: When the infusion pump is running, if the air-in-line sensor detects that the size of air bubble is larger than that of the preset limit, the device will trigger an alarm, stop running, make a high priority alarm sound, the screen appear with the message "Air-in-line" and the operation status indicator flash red at the same time.

Solution:

- 1) Click the "Confirm" button on the screen to clear the alarm and the message "Air-in-line" disappears.

- 2) To remove air bubbles from the infusion line, close the roller clamp, open pump door, take IV infusion set out, check whether there is air bubbles in the line, shake and move the air bubbles to the drip chamber by hands if there is, reinstall the IV infusion set, close the pump door, open the roller clamp, press the Start/Stop key or click the Start button to restart infusion.
- 3) Check if the air-in-line sensor is clean. If sensor probe is dirty, uninstall the IV infusion set, wipe clean the sensor probe with alcohol, reinstall the IV infusion set, and restart infusion.
- 4) If there is still an Air-in-line alarm, change to a new IV infusion set, install the IV infusion set and restart.
- 5) The air-in-line alarm will be activated too if the infusion line between the infusion bag and the pump is occluded. Remove the occlusion in infusion line and restart infusion.

8.7 Battery Empty Alarm

Cause: When the internal battery is running out, the device will trigger an alarm, stop running, make a high priority alarm sound, the screen appear with the message "Battery Empty" and the operation status indicator flash red at the same time, and the device will stop running and power off after 3 minutes.

Solution: The external power supply should be used immediately. When plugged in the external power supply, the battery charge light goes on and the battery starts charging. When the battery is fully charged, the battery charge indicator goes out.

8.8 Battery & External Power Disconnect Alarm

Cause: When the Infusion pump is running, the external power is disconnected, and the device does not detect the battery signal or the battery is disconnected unexpectedly, the device will trigger an alarm, the screen is black, the operation status indicator flash red at the same time, and the sound and light continue to alarm for 3 minutes before the device automatically power off.

Solution: Use external power supply or battery supply, and restart the device after power supply.

8.9 Motor Error Alarm

Cause: When an error is detected in the motor feedback signal (too slow or too fast, or wrong direction of motor operation etc.), or the sensor detection of push handle position does not match the cumulative amount of infusion, the device will trigger an alarm, stop running, make a high priority alarm sound, the screen appear with the message "Motor Error" and the operation status indicator flash red at the same time.

Solution: Click the "Confirm" button on the screen to clear the alarm. Start the infusion again, still report the fault alarm, please contact our service personnel.

8.10 Communication Error Alarm

Cause: When the communication of the device monitoring CPU is incorrect, the device will trigger an alarm, stop running, make a high priority alarm sound, the screen appear with the message "Communication Error" and the operation status indicator flash red at the same time.

Solution: Click "Confirm" button on the screen to clear the alarm sound. Press the Power on/off key to shut down the device and restart the device. If the fault alarm is still reported, please contact our service personnel.

8.11 Battery Error Alarm

Cause: When the external power is inserted on the device, the device does not detect the battery signal or the battery is disconnected unexpectedly, the device will trigger an alarm, stop running, make a high priority alarm sound, the screen appear with the message "Battery Error" and the operation status indicator flash red at the same time.

Solution: Click "Confirm" button on the screen to clear the alarm sound. Press the Power on/off key to shut down the device and restart the device. If the fault alarm is still reported, please contact our service personnel.

8.12 KVO Alarm

Cause: When KVO is enabled and the infusion is complete, the device will automatically convert to the KVO Rate to continue operation. At the same time, the device will trigger high priority alarm and sound alarm, the screen appear with the message "KVO" and the operation status indicator will flash red at the same time.

Solution: Click the "Confirm" button on the screen to clear the alarm. The message "KVO" disappear. The device can be reset

according to operating steps.

8.13 KVO End Alarm

Cause: When the KVO state runs for 30 minutes until KVO task is completed, the device will trigger an alarm, stop running, make a high priority alarm sound, the screen appear with the message "KVO End" and the operation status indicator flash red at the same time.

Solution: Click the "Confirm" button on the screen to clear the alarm. The message "KVO End" disappear. The device can be reset according to operating steps.

8.14 Standby End Alarm

Cause: When the device is in standby and the standby is over, the device will trigger high priority alarm and sound alarm, the screen appear with the message "Standby End" and the operation status indicator flash red at the same time.

Solution: Click the "Confirm" button on the screen to clear the alarm.

8.15 No AC Power Alarm

Cause: When the device is powered on without the network power and use battery power supply, the device will trigger an alarm, make a low priority alarm sound, the screen appear with the message "No AC Power" and the operation status indicator steady on yellow at the same time.

Solution: Click the "Confirm" button on the screen or connect

to an external power supply to clear the alarm.

8.16 Call Back Alarm

Cause: The device is ready to start the infusion, but the device is not started and the device is placed without operation for the set time, the device will trigger an alarm, make a low priority alarm sound, the screen appear with the message "Call Back" and the operation status indicator steady on yellow at the same time.

Solution: Click the "Confirm" button on the screen to clear the alarm.

8.17 Low Battery Alarm

Cause: When the internal battery is low, the device will trigger an alarm, make a low priority alarm sound, the screen appear with the message "Low Battery" and the operation status indicator steady on yellow at the same time. If the Infusion pump is infusing, the device will not stop infusing.

Solution: The external power supply should be used immediately. When plugged in the external power supply, the battery charge indicator lights up, the battery starts charging, and the message "Low battery" disappears, the battery icon shows the dynamic effect of charging. When the battery is fully charged, the battery charge light goes out.

8.18 Near End of Infusion Alarm

Cause: When the remaining time is less than or equal to the set near end of infusion time, the device will trigger an alarm, make

a low priority alarm sound, the alarm indicator area at the top of the screen appear with the message "Near End Of Infusion" and the operation status indicator steady on yellow at the same time, and the Infusion pump continues to infusion does not stop.

Solution: Click the "Mute" button on the right of the alarm prompt area to suspend the alarm sound. Focus on the amount of fluid remaining in the Infusion pump and the time remaining, and wait for the Infusion pump infusion to complete.

8.19 Drip Rate Error Alarm

Cause: When the device is used in conjunction with a drip rate sensor, when the deviation between the drip rate and the set infusion flow rate exceeds 50%, the device emits a high priority alarm sound, stops operation, the screen displays the word "Drip rate error", and the status indicator light flashes red at the same time.

Solution: Click the "Confirm" button on the screen to clear the alarm. Check if the installation of the drop sensor is normal, and restart the infusion after troubleshooting the problem.

8.20 CC Line Occlusion Alarm

Cause: When the pressure measured in the infusion line of the CC pressure disc is too high and exceeds the alarm limit. Causes of occlusion, such as drive system, syringe, patient infusion site, etc.

Solution: Click the "Confirm" button on the screen to clear the alarm. Before restarting the infusion, identify and eliminate the

cause of the occlusion, such as checking the drive system, syringe, patient infusion site, etc.

8.21 CC Pressure Disc Out Alarm

Cause: The CC pressure disc has been removed from the CC pressure transducer during infusion.

Solution: Click the "Confirm" button on the screen to clear the alarm. Reinstall or replace the CC pressure disc and start the infusion.

8.22 Needle Fall off Alarm

Cause: During the infusion process, the needle becomes detached from the patient's injection site.

Solution: Click the "Confirm" button on the screen to clear the alarm. Re-puncture, check that the infusion line is normal, and then start the infusion.

9 System Parameter setting

9.1 Bed Number

The Bed number can be set on the Home-Setting- Bed number page.

9.2 Brightness

On the Home- Setting- Brightness page, brightness of the display can be adjusted between 1 and 10 level by clicking on the + or – sign. After brightness setting is completed, click the "Confirm" button to return to the previous page.

9.3 Alarm Sound Volume

On the Home- Setting- Volume- page, alarm sound volume can be adjusted between 1 and 5 level by clicking on the + or – sign. After sound volume setting is completed, click the "Confirm" button to return to the previous page.

9.4 Occlusion Pressure Level

When using non-CC special infusion tube, in the "Home - Settings - Pressure Settings" section, the blocking pressure alarm level can be set by clicking the corresponding level number button to complete the setting. After setting up, click the "Confirm" button to return to the previous page.

When using CC special infusion tube, the occlusion pressure Level can be set on the Home- Setting- CC Pressure Setting page. Occlusion pressure threshold: (25-1000mmHg).

Note: $kPa \times 7.5 = mmHg$, $mmHg \times 0.133 = kPa$

9.5 Air Bubble Detection Sensitivity

Set the bubble level in "Home - Settings - Bubble Settings", and the smaller the bubble level, the more sensitive it is. Click the corresponding level number button to complete the setting. After setting up, click the "Confirm" button to return to the previous page.

9.6 Bolus Setting

The Bolus Rate and Bolus VTBI can be set on the Home-Setting- Bolus page. Click the corresponding parameter value to set. After the Settings are complete, click the Back button to return to the previous page.

9.7 Purge Setting

The Purge Rate and Purge VTBI can be set on the Home-Setting- Purge page. Click the corresponding parameter value to set. The values set in the Purge setting will not affect the Bolus Rate and Bolus VTBI.

9.8 Call Back Time Setting

On the Home- Setting- Call Back Time page, can set the Call Back Alarm time when the device is placed without operation and not running.

9.9 KVO Setting

On the Home- Setting - KVO page, set the KVO Mode and KVO Rate after the End Of Infusion.

Select the Constant KVO mode and the device will operate according to the currently set KVO Rate.

Select the Variable Speed KVO Mode, the device will automatically determine the KVO Rate level according to the current Infusion rate of the infusion operation, and run according to the KVO Rate of the currently set Infusion rate level.

Constant KVO Mode (V_{KVO} rate setting range: 0.10-5.00 mL/h, minimum step value 0.01 mL/h)

-When the infusion rate is $>V_{KVO}$: After the infusion task is completed, the pump automatically runs at the V_{KVO} rate to maintain venous patency.

-When the infusion rate is $\leq V_{KVO}$: After the infusion task is completed, the pump continues to run at the infusion rate to

maintain venous patency.

Variable Speed KVO Mode (V_{KVO} rate setting range: 0.10-5.00 mL/h, minimum step value 0.01 mL/h)

Users need to set the V_{KVO} rate separately for three scenarios:

- (a) $V_{KVO}(>10)$ rate for infusion rates > 10 mL/h,
- (b) $V_{KVO}(1-10)$ rate for infusion rates between 1-10 mL/h, and
- (c) $V_{KVO}(\leq 1)$ rate for infusion rates ≤ 1 mL/h.

The system will automatically matches the KVO rate based on the infusion rate:

-When the infusion rate is > 10 mL/h: After the infusion task is completed, the pump automatically runs at the $V_{KVO}(>10)$ rate to maintain venous patency.

-When the infusion rate is between 1-10 mL/h: After the infusion task is completed, the pump automatically runs at the $V_{KVO}(1-10)$ rate to maintain venous patency.

-When the infusion rate is ≤ 1 mL/h and the infusion rate is $> V_{KVO}(\leq 1)$ rate: After the infusion task is completed, the pump continues to run at the $V_{KVO}(\leq 1)$ rate to maintain venous patency.

-When the infusion rate is ≤ 1 mL/h and the infusion rate is $\leq V_{KVO}(\leq 1)$ rate: After the infusion task is completed, the pump continues to run at the infusion rate to maintain venous patency.

9.10 Screen Lock Time

Set the time for the display screen and device buttons to enter the locked state during device infusion operation in "Home - Settings - Automatic Lock Screen Settings".

If the lock screen time is set to 0, the automatic lock screen

function can be turned off.

In the locked screen state, except for the power button, all other buttons and screen areas are not operable.

9.11 Near End of Infusion Time Setting

The near end of infusion time can be set on the Home- Setting- NEOI page.

9.12 Prime Prompt Switch

On the Home- Setting- Prime prompt switch page, can choose whether to enable the Prime prompt, if this function is enabled, the "Prime" prompt page will appear when a new infusion task starts after each IV infusion set change.

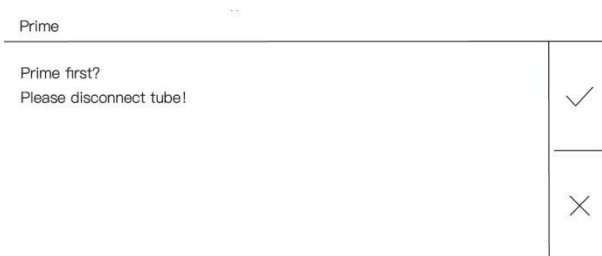

Figure 9-12 Prime prompt page

9.13 History Mode Switch

On the Home- Setting- History mode switch page, can choose whether to enable the History mode, if this function is enabled, the "Sure to load last treatment?" prompt page will be displayed after each power on.



Figure 9-13 Sure to load last treatment

9.14 IV Set Brand

When the device is not running, click the IV infusion set brand on the upper right corner of the interface, select the corresponding IV infusion set name, and the device will return to the infusion page. The selected brand for the IV infusion set will be shown on the upper right corner of the infusion page, which can remind the operator to use the right IV infusion set to maintain high infusion accuracy.

The calibration operation of IV infusion set, see Section 10.2 Accuracy calibration for IV infusion set.

9.15 Night Mode Setting

On the Setting- Maintenance- Night Mode page, can set the brightness or sound volume for daytime or nighttime, the setting method is the same as that for brightness and sound level.

Night Mode Enable <input checked="" type="checkbox"/>	Bright. 3 >	Volume 3 >
Start Time 18:00:00 >	Stop Time 08:00:00 >	
Return		

Figure 9-15 Night mode Setting

9.16 Date/Time Setting

The device of Time and date can be set on the Setting Maintenance-Date/Time page.

Date Setting Y.M.D		1	2	3	⌫	↶
🔍	2023.06.21	4	5	6	0	✓
		7	8	9	.	

Figure 9-16-1 Date setting

Time Setting H:M:S		1	2	3	⌫	↶
🔍	17:30:42	4	5	6	0	✓
		7	8	9	:	

Figure 9-16-2 Time setting

9.17 Maintenance

Maintain the device in “Setting - Maintenance”, Including the calibration of IV infusion set accuracy, system time settings, system language settings, factory resets, etc. Entering the Maintenance interface requires entering the engineer's maintenance password, password please consult the company's sales and service personnel.

IV infusion set calibration operation instructions see Section 10 of this manual.

10 Calibration

10.1 Accuracy Calibration for IV infusion set

The brand and specification IV infusion sets that have not been calibrated, or IV infusion sets belonging to different production lots with the calibrated IV infusion sets, need to be calibrated before use. In normal use, the IV infusion set should be re-calibrated every 6 months.

10.1.1 Enter infusion set accuracy calibration interface

Calibrate the accuracy of the infusion device in the "Home - System Maintenance - Consumables Maintenance" section.

10.1.2 Accuracy Calibration for IV infusion set

- 1) Same as the normal infusion operation, install the IV infusion set first, put the scalp needle into the beaker, place the beaker on the balance and clear the indicator to zero, and enter the page of "Setting- System Maintenance- Consumable Maintenance - Calibration Consumable".
- 2) Click Brand, select the brand of the IV infusion set to be calibrated, and return to the Calibration Consumable page.
- 3) Click Calibration range, select the high Rate interval or the low Rate (the calibration Rate of the low Rate is 200mL/h, and the output volume is 10mL; the calibration Rate of the high Rate is 1000mL/h, and the output volume is 50mL), return to the Calibration Consumable page, and pay attention to the selection of the scalp needle specifications that match the rate.
- 4) Click Calibration Start/Stop, the infusion pump will output a certain amount of solution according to the current calibration interval.

When the infusion was completed, the infusion pump automatically stopped running.

- 5) Check the balance reading, convert it to the actual solution volume, and input the actual solution volume in the Volume Output;
- 6) Turn to the next page and click OK to save the current calibration value.

10.2CC Calibration

10.2.1 Calibration tool

1. Pressure gauge (range 0-1400 mmHg) (tolerance +/-0.1% full scale accuracy)
2. Special infusion line with CC pressure disc.

10.2.2 Calibration steps

Insert the infusion line with the CC pressure disc into the CC pressure transducer, connect the infusion line to the pressure gauge, apply the required pressure to the infusion line. At each step, press the CAL soft key when the pressure to be calibrated is displayed on the pressure gauge.

Note: The calibration values shown on the display are for illustrative use only and may vary.

11 Precautions for Using Disposable Consumables

It's suggested to use the recommended consumables. The ambient temperature should be kept at least at 5 °C or above when a recommended consumable is used. The infusion accuracy will be compromised if ambient temperature is lower than 5 °C.

The recommended consumables are listed in the table below:

No	Brand	Model	Accuracy	Ambient temperature
1	MDK	P-B-11	±3%	+5℃~+40℃
2	MDK(enteral feeding)	EF-BS1-P1	±4%	+5℃~+40℃
3	Terumo	1TB*U800B	±4%	+5℃~+40℃

The consumable used must have a medical device product registration certificate, and the consumable specifications are selected in the same specification as the recommended consumable brand. consumable Installation Methods See 7.3.1 Install/replace consumable.

In order to ensure infusion accuracy, when the ambient temperature changes significantly, the device needs to be re-calibrated, calibration method See Section 10 Accuracy Calibration for consumable.

Please strictly follow the requirements described in Section 10 to calibrate and use the consumable when change to a new consumable from a different manufacturer. Otherwise, the infusion accuracy may be compromised.

12 Technical Specification

According to IEC60601-2-24 standard, we tested and obtained the trumpet and flow rate graphs under the conditions of 1mL, 25mL, positive and negative back pressure, etc. The specific data are reflected in the IEC60601-2-24 test reports, and the relevant graphs will update in this section accordingly.

This product is numbered according to the technical requirements

of medical devices:

- 1) The methods of controlling Bolus volume before occlusion: The pressure in the occlusion pipeline is released to control the bolus volume by controlling the inversion of the stepper motor.
- 2) Storage time for the electronic memory after power off: same as the product lifetime.
- 3) The maximum volume that the pump can deliver under a single fault condition: 0.4 mL.
- 4) Device calibration is measured in ml.
- 5) The methods used to avoid overflow or underflow due to device failure: to prevent overflow or underflow by using drop speed sensor to measure flow rate.
- 6) Minimum flow rate performance curve (1 mL/h)
 - a. The rising curve for MDK IV infusion set with the minimum flow rate during the first two hours of operation.

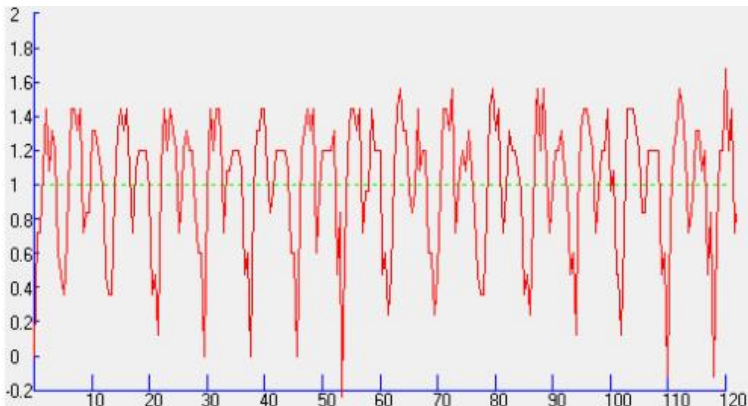

In the above figure, the dashed line shows the set flow rate (1 mL/h in this figure), and the solid line is the continuous connection line for the average flow rate during a sampling period.

- b. The trumpet curve for MDK IV infusion set with the minimum flow rate during the second hour of operation.

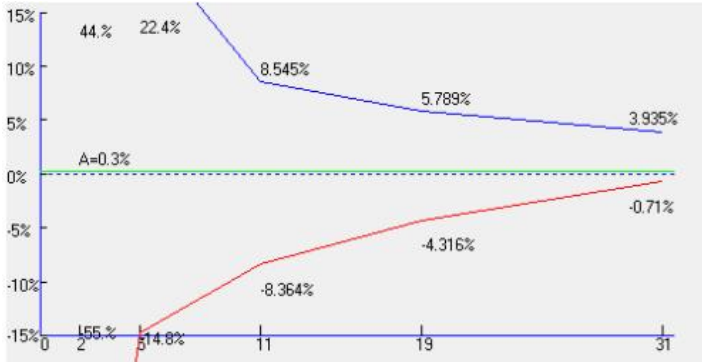

The dashed line in green color is the final value that the infusion error of the device is eventually converging to. The solid blue line above the dashed line is the maximum positive deviation during the second hour of operation. The solid red line below the dashed line is the maximum negative deviation during the second hour of operation.

- c. The trumpet curve for MDK IV infusion set with the minimum flow rate during the last hour of the run.

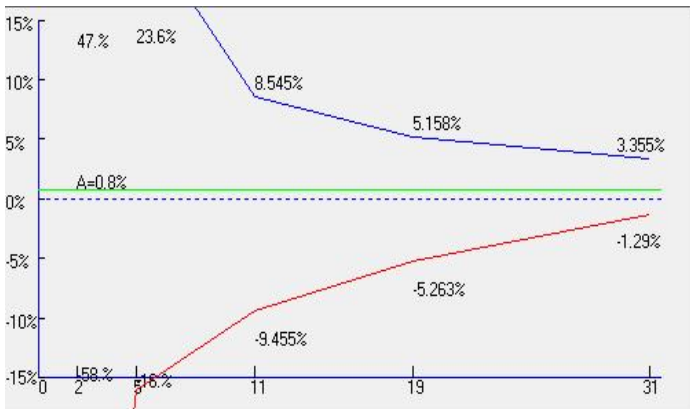

The green dashed line is the value where the device perfusion

error finally converges. The solid blue line above the dashed line is the maximum positive deviation within the hour of the run. The solid red line below the dashed line is the maximum negative deviation within the last hour

7) Intermediate flow rate performance curve (25 mL/h)

- a. The rising curve for MDK IV infusion set with the intermediate flow rate during the first two hours of operation.

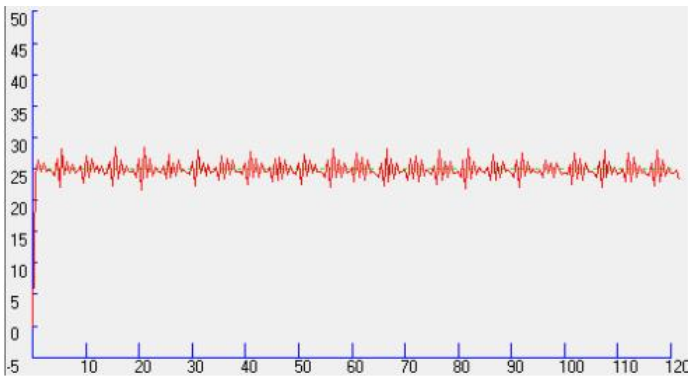

- b. The trumpet curve for MDK IV infusion set with the intermediate flow rate during the second hour of operation.



- c. The trumpet curve for MDK IV infusion set with the intermediate

flow rate during the last hour of the run.

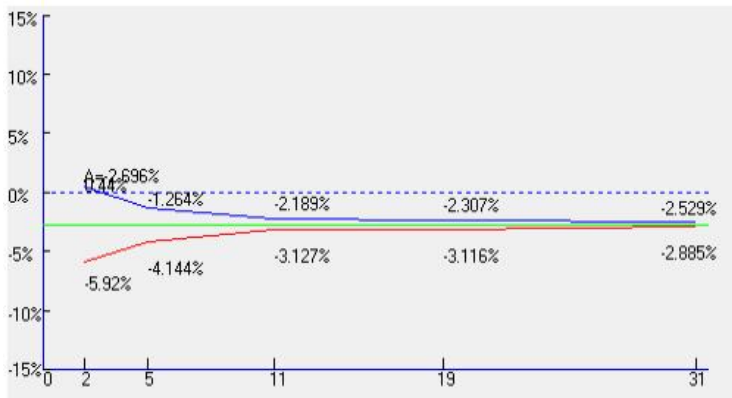

The green dashed line is the value where the device perfusion error finally converges. The solid blue line above the dashed line is the maximum positive deviation within the last hour of the run. The solid red line below the dashed line is the maximum negative deviation within the last hour.

- 8) Intermediate flow rate and back pressure +13.33kPa performance curve
 - a. The rising curve for MDK IV infusion set with the Intermediate flow rate and back pressure +13.33kPa during the first 2h of the test period.

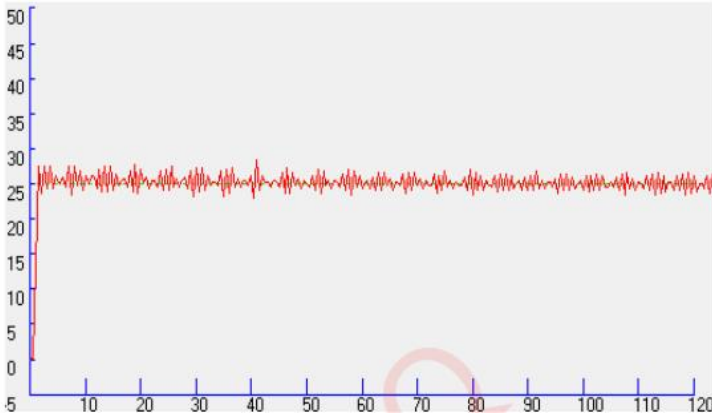

In the above figure, the dashed line shows the set flow rate (25 mL/h in this figure), and the solid line is the continuous connection line for the average flow rate during a sampling period.

- b. The trumpet curve for MDK IV infusion set with the Intermediate flow rate and back pressure +13.33kPa during the second hour of the test period.

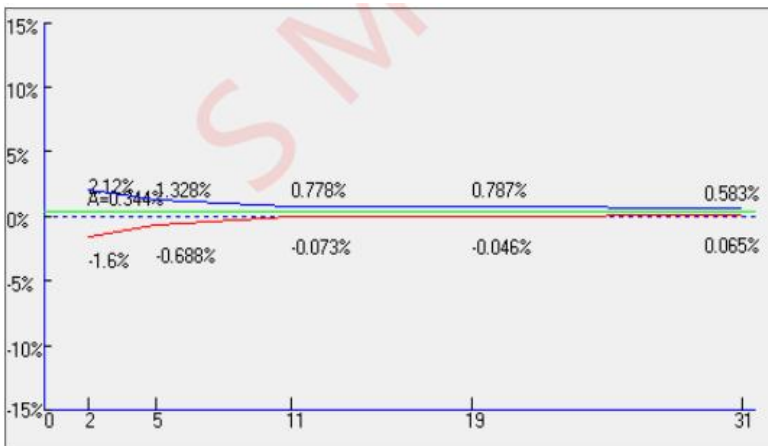

The dashed line in green color is the final value that the infusion error of the device is eventually converging to. The solid blue line above

the dashed line is the maximum positive deviation during the second hour of the test period. The solid red line below the dashed line is the maximum negative deviation during the second hour of the test period.

9) Intermediate flow rate and back pressure -13.33kPa performance curve

a. The rising curve for MDK IV infusion set with the Intermediate flow rate and back pressure -13.33kPa during the first 2h of the test period.

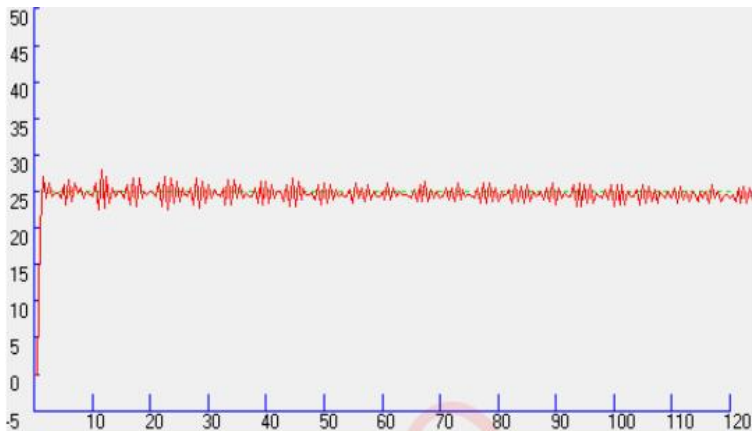

In the above figure, the dashed line shows the set flow rate (25 mL/h in this figure), and the solid line is the continuous connection line for the average flow rate during a sampling period.

b. The trumpet curve for MDK IV infusion set with the intermediate flow rate and back pressure -13.33kPa during the second hour of the test period.

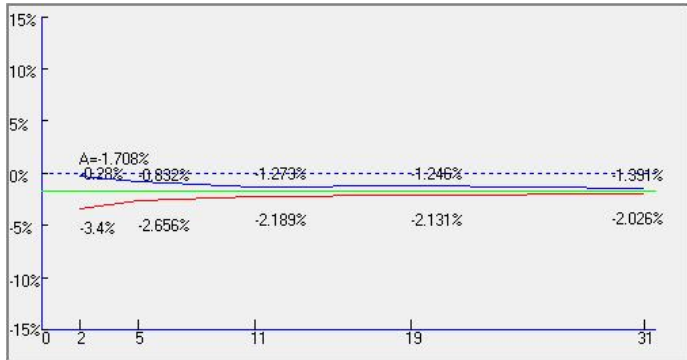

The dashed line in green color is the final value that the infusion error of the device is eventually converging to. The solid blue line above the dashed line is the maximum positive deviation during the second hour of the test period. The solid red line below the dashed line is the maximum negative deviation during the second hour of the test period.

- 10) Intermediate flow rate and below distance 0.5 meter performance curve
 - a. The rising curve for MDK IV infusion set with the Intermediate flow rate and the supply container below the pump mechanism at a distance of 0.5m during the first 2h of the test period.

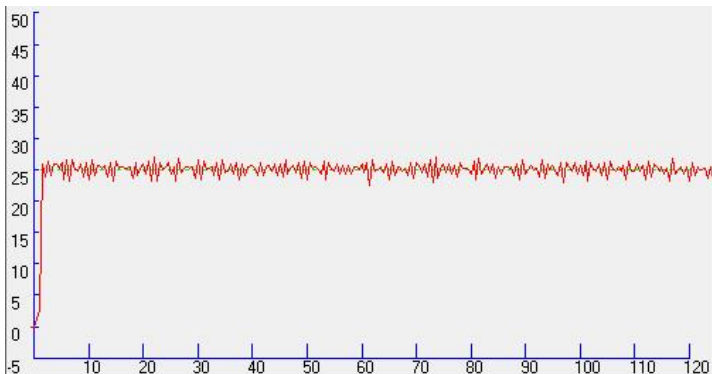

In the above figure, the dashed line shows the set flow rate (25 mL/h in this figure), and the solid line is the continuous connection line for the average flow rate during a sampling period.

- b. The trumpet curve for MDK IV infusion set with the Intermediate flow rate and the supply container below the pump mechanism at a distance of 0.5m during the second hour of the test period.

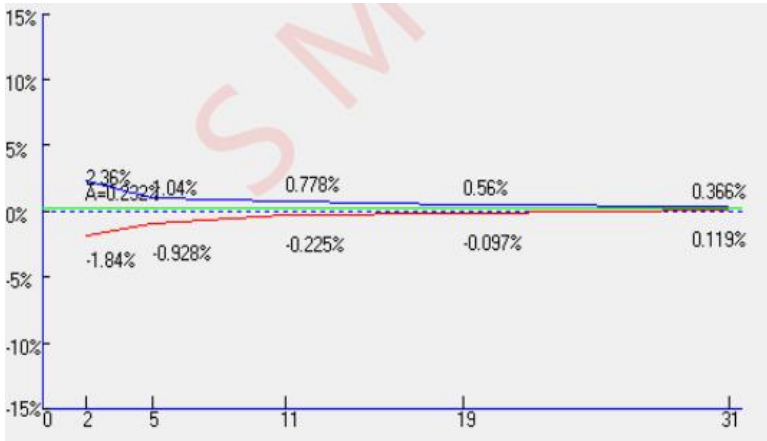

The dashed line in green color is the final value that the infusion error of the device is eventually converging to. The solid blue line above the dashed line is the maximum positive deviation during the second hour of the test period. The solid red line below the dashed line is the maximum negative deviation during the second hour of the test period.

13 Restore to Factory Setting

Default factory setting as below:

No.	Parameter	Factory presets
1	Brightness level	level 3
2	System sound level	level 3
3	Bubble level	level 3

4	Night mode sound level	level 3
5	Night mode brightness level	level 3
6	Occlusion pressure level	1000mmHg
7	Night mode	Close
8	Infusion mode	RVT mode
9	KVO	Constant KVO
10	KVO rate	1.00 mL/h
11	Call Back Time	2 min
12	Near End Of Infusion time	5 min
13	Auto screen lock time	5 min
14	Night mode start time	19:00:00
15	Night mode end time	09:00:00
16	Bolus rate	1200.00 mL/h
17	Purge rate	1200.00 mL/h
18	Bolus volume	5.00 mL
19	Purge volume	15.00 mL

14 Use, Maintenance and Removal of the Internal Battery

The device has an internal rechargeable lithium battery with the following specification: 21700/4800mAh*2PCS.

Daily maintenance of the battery:

- 1) When the pump is not used for a long time, the internal battery should be fully charged at least once for every 3 months by connecting the device to the mains power to help saving the battery life.
- 2) Contact the customer service immediately if the internal battery cannot be charged or cannot work normally. Do not disassemble it by yourself. For the healthcare providers who have the ability to repair a device, we will provide training to the related personnel

from these facilities.

The device has a internal disposable button battery designed to last longer than 8 years, when the set time is exceeded, need to be disposed with the device in accordance with the instructions for waste disposal in this manual 16.

15 Service and Maintenance

Check the pump before use:

- 1) Check whether there are foreign objects inside the power outlet (such as drug solution residue), and confirm that the device startup self-test is normal.
- 2) Select the correct IV infusion set specification, check the battery power, and charge it in time when the power is low.

During use:

- 1) To avoid giving an incorrect dosage of drug to a patient, please disconnect the pump from the patient before changing a device.
- 2) Please make sure that the infusion line is not kinked. Insert the needle to the vein on a part of the patient's body where it is not likely to be squeezed or pressed.
- 3) To prevent the spilled drug solution on the pump surface from getting into the inside of the device, wipe it dry immediately if there is a bolus.

Storage and daily maintenance:

- 1) To keep the device clean, wipe it clean for at least once a month, which can prevent the corrosion caused by the drug solution and avoid the mobility of the mechanical parts being affected by the dried solution.

- 2) Use a clean and damp cloth or an alcohol pad to wipe clean the device. Take caution to avoid any liquid from entering the device. If disinfection is required, commonly used disinfectants can be used. After using the disinfectant, after wetting with a soft cloth in water, wring out the soft cloth for scrub treatment. When using disinfectants, follow their instructions.
- 3) Check the Low battery Alarm time of the device at least once a month. Make the device standby when the battery is low in non-clinical use, start timing when you hear the alarm of "low battery", and the alarm time should be more than 30 minutes.
- 4) Keep the surface of the air bubble sensor probe clean. A dirty probe will reduce the sensor's sensitivity in air bubble detection or cause false alarm. Take caution when cleaning the probe to avoid causing any damage.

16 Waste Disposal

16.1 Battery

Please follow local regulations to dispose of used batteries.

16.2 IV infusion set

After use, please dispose of the consumables in accordance with the relevant medical waste disposal regulations.

16.3 Infusion pump

This device is designed to last 8 years and should be scrapped after it has exceeded the lifetime. End-of-life Infusion pumps can be sent back to the dealer who sold the product or to the Company

for proper recycling.

17 Electromagnetic Compatibility

Special precautions regarding Electromagnetic Compatibility (EMC) are required for this device. Must install and use in accordance with the electromagnetic compatibility information specified in this instruction.

Portable and mobile RF communication devices may have an impact on this device.

Must use the cables and accessories provided by this device, and the cable information as follows:

Product name	Length
Power adapter	2.9m

In addition to cables (transducers) sold as spare parts for internal components, the use of accessories and cables (transducers) other than specified may result in an increase in device or system emission or a decrease in immunity.

Devices or systems should not be used close to or stacked with other devices, and if they must be accessed or stacked, observe to verify that they can run normally in the configuration they are using.

The basic performance is to operate on a network power supply (including an internal battery) connection.

Name	Description
The network power supply (including the internal battery) is connected to run	At the intermediate rate of 25.00mL/h and the VTBI of $\geq 10\text{mL}$, start to operation, infusion accuracy error less than $\pm 4\%$ and the operation is normal during the process, there should be no abnormal phenomena and failures.

Guidance and manufacture’s declaration – electromagnetic emission

Guidance and manufacture’s declaration – electromagnetic emission

The device is expected to be used in the following specified electromagnetic environment, and the purchaser or user should ensure that it is used in this electromagnetic environment:

Emission test	Compliance	Electromagnetic environment guidance
RF emissions CISPR 11	Group 1	The device only uses RF energy for its internal functions, so its RF emission is very low and the possibility of interference to nearby electronic devices is very low
RF emissions CISPR 11	Class A	The device is suitable for use in non household and all facilities that are not directly connected to the public low-voltage power supply network of household residential areas.
Harmonic emissions IEC 61000-3-2	Not applicable	
Voltage fluctuations / flicker emissions IEC 61000-3-3	Not applicable	

Guidance and manufacture’s declaration – electromagnetic immunity

Guidance and manufacture’s declaration – electromagnetic immunity

The Infusion pump is intended for use in the electromagnetic environment specified below. The customer or the user of Infusion pump should assure that it is used in such an environment.

Immunity test	IEC 60601 test level	Compliance level	Electromagnetic environment guidance
Electrostatic discharge (ESD) IEC 61000-4-2	±8KV contact ±15 KV air	±8KV contact ±15KV air	The ground should be made of wood, concrete, or ceramic tiles. If the ground is covered with

			synthetic materials, the relative humidity should be at least 30%
Electrical fast transient/burst IEC 61000-4-4	±2KV for power supply lines ±1 KV signal input/output	±2 KV for power supply lines Not applicable	The network power supply should have the quality used in typical commercial or hospital environments
Surge IEC 61000-4-5	±1 KV line to line ±2 KV line to ground	±1 KV line to line Not applicable	The network power supply should have the quality used in typical commercial or hospital environments
Voltage dips, short interruptions and voltage variations on power supply input lines IEC 61000-4-11	<5%U _T , 0.5 cycle (>U _T , >95% voltage dips) 40%U _T , 5 cycle (> U _T , 60% voltage dips) 70%U _T , 25 cycle (>U _T , 30% voltage dips) <5%U _T , 5 cycle (>U _T , >95% voltage dips)	<5%U _T , 0.5 cycle (>U _T , >95% voltage dips) 40%U _T , 5 cycle (> U _T , 60% voltage dips) 70%U _T , 25 cycle (>U _T , 30% voltage dips) <5%U _T , 5 cycle (>U _T , >95% voltage dips)	The network power supply should have the quality suitable for typical commercial or hospital environments. If the user of the device needs to operate continuously during a power outage, it is recommended to use an uninterruptible power supply or battery power supply for the device.

Power frequency (50/60Hz) magnetic field IEC 61000-4-8	400A/m	400 A/m	The power frequency magnetic field should have the horizontal characteristics of the power frequency magnetic field in typical commercial or hospital environments

Note: UT is the a.c. mains voltage prior to application of the test level.

Guidance and manufacture's declaration - electromagnetic immunity - For life support device and systems

Guidance and manufacture's declaration – electromagnetic immunity			
The Infusion pump is intended for use in the electromagnetic environment specified below. The customer or the user of Infusion pump should assure that it is used in such an environment.:			
Immunity test	IEC 60601 test level	Compliance level	Electromagnetic environment guidance
Conducted RF IEC61000-4-6	3 V(Valid value) 150 kHz~ 80MHz (expect the ISM bands between ^a)	10V	Portable and mobile RF communication devices should not be used closer to any part of the device, including cables, than the recommended isolation distance. The distance should be calculated using a formula corresponding to the transmitter frequency. Recommended isolation distance
Radiated RF IEC61000-4-3	10V(Valid value) 150 kHz~ 80MHz (ISM bands	10V/m	

	<p>between ^{a)}</p> <p>10V /m</p> <p>80MHz~2.5GHz</p>		<p>$d = 1.2\sqrt{(P)}$ 150kHz-80MHz</p> <p>$d = 1.2\sqrt{(P)}$ 80MHz-800MHz</p> <p>$d = 2.3\sqrt{(P)}$ 800MHz-2.5GHz</p> <p>Note:</p> <p>P—According to the maximum rated output power of the transmitter provided by the transmitter manufacturer, in watts (W);</p> <p>d —Is the recommended isolation distance in meters (m).^b</p> <p>The field strength of a fixed RF transmitter is determined by surveying the electromagnetic field c, and should be lower than the corresponding level in each frequency ranged.</p> <p>Interference may occur near devices marked with the following symbols.</p> 
--	--	--	--

NOTE 1 At 80 MHz and 800 MHz, the higher frequency range applies.

NOTE 2 These guidelines may not apply in all situations. Electromagnetic propagation is affected by absorption and reflection from structures, objects and people.

a The ISM bands between 150kHz and 80MHz means 6.765MHz~6.795 MHz、13.553MHz~13.567 MHz、26.957MHz~27.283 MHz 和 40.66MHz~40.70MHz.

b The ISM bands between 150kHz~80MHz and 80M Hz~2.5GHz compliance level, is used to reduce the possibility of interference caused by mobile/portable communication devices accidentally brought into the patient's area. For this purpose, an additional factor of 10/3 is used to calculate the recommended isolation distance of the transmitter within these frequency ranges.

c Fixed transmitter. For example, the field strength of base stations for wireless (cellular/wireless) telephones and ground mobile radios, business radios, AM and FM radio broadcasts, and television broadcasts cannot be accurately predicted in theory. To evaluate the electromagnetic

environment of fixed RF transmitters, consideration should be given to the investigation of electromagnetic sites. If the measured field strength of the location where the infusion pump is located is higher than the applicable RF compliance level mentioned above, the infusion pump should be observed to verify its normal operation. If abnormal performance is observed, additional measures may be necessary, such as adjusting the direction or position of the infusion pump.

d In the entire frequency range of 150kHz to 80MHz, the field strength should be less than 3V/m

Recommended isolation distances between portable and mobile radio frequency communication devices and devices or systems
—For life support device and systems

Recommended isolation distance between portable and mobile RF communication device and infusion pumps

The device is expected to be used in an electromagnetic environment with controlled radio frequency radiation disturbance. Based on the maximum rated output power of communication devices, buyers or users can prevent electromagnetic interference by maintaining the minimum distance between portable and mobile RF communication devices (transmitters) and devices as recommended below.

Maximum rated output power of the transmitter W	Isolation distance corresponding to different frequencies of the transmitter/m			
	150kHz ~ 80MHz expect the ISM bands) $d = 1.2 \sqrt{P}$	150kHz ~ 80MHz (ISM bands) $d = 1.2 \sqrt{P}$	80MHz~800MHz $d = 1.2 \sqrt{P}$	800MHz~2.5GHz $d = 2.3 \sqrt{P}$
0.01	0.12	0.12	0.12	0.23
0.1	0.38	0.38	0.38	0.73
1	1.2	1.2	1.2	2.3
10	3.8	3.8	3.8	7.3
100	12	12	12	23

For the maximum rated output power of transmitters not listed in the above table, it is recommended to isolate the distance d in meters (m), which can be determined by the

formula in the corresponding transmitter frequency column. Here, P is the maximum rated output frequency of the transmitter provided by the transmitter manufacturer, in watts (W).

Note 1: At the frequency points of 80 MHz and 800 MHz, the formula for the higher frequency band is used.

Note 2: The power frequency medical frequency band between 150 kHz and 80 MHz refers to 6.765 MHz to 6795 MHz, 13.553 MHz to 13567 MHz, 26.957 MHz to 27.283 MHz, and 40.66 MHz to 40.70 MHz.

Note 3: The additional factor of 10/3 is used to calculate the recommended isolation distance for transmitters in the engineering and medical frequency bands of 150 kHz to 80 MHz and the frequency range of 80 MHz to 2, 5 GHz, in order to reduce the possibility of interference caused by portable/mobile communication devices accidentally brought into the patient's area.

Note 4: These guidelines may not be suitable for all situations. Electromagnetic propagation is influenced by the absorption and reflection of buildings, objects, and the human body.

18 Antistatic Precautions

The Infusion pumps have been tested and comply with medical device standard IEC 60601-1-8.

When using this device, the user should not touch the pins of connectors marked with an electrostatic discharge warning symbol and should not connect to these connectors unless electrostatic discharge precautions are used.

The operator should be aware of the following things:

- a) Unless appropriate preventive measures have already been taken, do not use hand or hand tool to touch connectors with electrostatic discharge warning signs. Preventive measures include:
 - 1) Methods for preventing electrostatic charge accumulation (such as air conditioning, air humidification, floor conductive coating or Non-synthetic clothing);
 - 2) Discharge electrostatic charge from

human body to the framework of device, or to the ground, or to a large piece of metal; 3) Use a wrist band to connect human body to the device or to the ground.

b) All staff who may be in contact with connectors with electrostatic discharge warning signs should receive training, including all clinical/biomedical engineering and healthcare personnel.

c) Electrostatic discharge training should include the introduction of static charges in the theory of physics, the voltage that may be produced in normal practice, and the damage to the electronic components caused by the electrostatic charge from an operator. Further, methods for how to prevent electrostatic charge accumulation should be provided, as well as how and why to discharge the electrostatic from human body to the framework of device or to the ground, and how to use wrist band to connect someone’s body to the device or to the ground.

19 Packaging and Accessories

The list of recommended accessories for use with this device (single unit) is as follows:

Accessories	Qty	Unit
IFU	1	Book
Power adapter	1	set
Other accessories can be found in the packing list.		



Legal manufacturer: MDKMed Medical Technology Co., Ltd.

Address: 502A, Building 7, No. 22, Xinyan Road, Donghu Street,
Linping District, Hangzhou City, Zhejiang Province, P. R China 311323

After sale service: MDKMed Medical Technology Co., Ltd.

Tel: 400-880-8392

Email: sales@graseby.com

Web: <http://www.graseby.com>

Revision date: 13-03-2025

Part No.: 07.01.0174A



European Authorized Representative:

MedNet EC-REP C IIb GmbH

Borkstrasse 10

48163 Münster, Germany